

A sum rule for the dispersion relations of the rational Harper equation

Y Last and M Wilkinson†

Department of Physics, Technion—Israel Institute of Technology, Haifa, 32000, Israel

Received 23 April 1992, in final form 22 July 1992

Abstract. We derive an exact sum rule satisfied by the dispersion relations of the commensurable case of Harper's equation. We use this result to derive a lower bound for the total bandwidth of the spectrum and to provide a stronger analytical justification for a result due to Thouless concerning the total bandwidth when the commensurability is a high order rational.

1. Introduction

Harper's equation

$$\psi_{n+1} + \psi_{n-1} + 2\alpha \cos(2\pi\beta n + \Delta)\psi_n = E\psi_n \quad (1.1)$$

is a discrete Schrödinger equation which models an electron moving in a plane with a perpendicular magnetic field, in a spatially periodic potential (Harper 1955, Rauh 1974, 1975). It is also (when β is an irrational number) a tight-binding model for an electron in an incommensurately modulated potential. The spectrum has some interesting properties. When β is an irrational number, the spectrum is generically a Cantor set (Azbel 1964, Bellissard and Simon 1982), and numerical results indicate that when $\alpha = 1$ (called the critical point) the measure of this set vanishes, and that it has a beautiful recursive structure (Hofstadter 1976). When β is the ratio of two integers, $\beta = p/q$ (where p and q are relatively prime), Bloch's theorem is applicable and the spectrum consists of q bands, with dispersion relations $E = \epsilon_\nu(k, \Delta)$, $\nu = 1, \dots, q$. Thouless (1983, 1990) has discovered a remarkable property of the total bandwidth S (the union of the spectra over all values of Δ) at the critical point the asymptotic behaviour in the limit $q \rightarrow \infty$ is independent of p and given by

$$\lim_{q \rightarrow \infty} qS = \frac{32C}{\pi} \quad (1.2)$$

where $C = 0.915\,965\,59\dots$ is Catalan's constant (Abramowitz and Stegun 1972). The derivation is based upon a WKB approximation, which is only valid for small β : in fact a derivation has only been given for the two special cases $p = 1$ and $p = 2$.

† Permanent address: Department of Physics and Applied Physics, John Anderson Building, University of Strathclyde, Glasgow G4 0NG, UK.

The extension to general values of p and q does not appear to be easy (Thouless 1990, Watson 1991, Thouless and Tan 1991a). It is a very surprising feature of this result that although this is an asymptotic result and Thouless's derivation depends in an essential way upon β being small, numerical results indicate that it holds for all rational β with large denominator.

This paper makes two contributions towards establishing an analytical basis for equation (1.2). Firstly (in section 2) we derive an exact equality concerning the dispersion relations at the critical point, which holds for all (relatively prime) p, q , and which is closely related to (1.2). This equality leads directly (section 3), to the lower bound $4/q$ for the total bandwidth at the critical point. Secondly, (in section 4) we combine this new exact equality with some earlier semiclassical results by one of us (Wilkinson 1987), to argue that if (1.2) holds for sequences of rationals obeying $\beta_n \rightarrow 0$, then it should also hold for sequences of rationals obeying $\beta_n \rightarrow \beta_0$, where β_0 is any fixed rational. Some numerical illustrations of these results are included in section 5.

2. An exact sum rule

The dispersion relations for the bands are given by the implicit equation

$$P_\alpha(E) = 2 \cos kq + 2\alpha^q \cos \Delta q \quad (2.1)$$

where $P_\alpha(E)$ is a polynomial of degree q (Bellissard and Simon 1982), i.e.

$$\epsilon_\nu(k, \Delta) = f_\nu(2 \cos kq + 2\alpha^q \cos \Delta q) \quad (2.2)$$

where $f_\nu(x)$ is the ν th branch of the inverse function of $P_\alpha(E)$. We will show that when $\alpha = 1$ the derivatives of the function $P_\alpha(E)$ at its zero crossings satisfy the exact equality

$$\sum_{\nu=1}^q \frac{1}{|P'_1(E_\nu)|} = \frac{1}{q} \quad (2.3)$$

where E_ν are the q zeros of $P_1(E)$. This result gives the sum of the curvatures of the dispersion relations at the saddle points in k, Δ space. It is also clearly closely related to (1.2): if we were to approximate $P_1(E)$ by a linear function with slope $P'_1(E_\nu)$ at each branch, from (2.3) we would estimate that the total bandwidth would be $8/q$, instead of the expected value $9.3299\dots/q$.

To prove (2.3) we make use of another exact result previously derived by Avron, van Mouche and Simon (1990), for the intersection over Δ of the band spectra for rational β . They show that the total bandwidth of the intersection spectrum S_- , for $\alpha < 1$, is given by the exact result

$$S_- = 4(1 - \alpha). \quad (2.4)$$

From (2.1), we see that the intersection of the bands over Δ corresponds to values of $P_\alpha(E)$ in the range

$$-2(1 - \alpha^q) \leq P_\alpha(E) \leq 2(1 - \alpha^q). \quad (2.5)$$

In the limit $\alpha \rightarrow 1$ both S_- and this range of $P_\alpha(E)$ vanish, and the total bandwidth of the intersection spectrum can be expressed in terms of the derivatives of $P_\alpha(E)$ at its zero crossings, in the sense that

$$S_- \sim 4(1 - \alpha^q) \sum_{\nu=1}^q \frac{1}{|P'_\alpha(E_\nu)|}. \tag{2.6}$$

Thus, we have

$$\sum_{\nu=1}^q \frac{1}{|P'_1(E_\nu)|} = \lim_{\alpha \rightarrow 1} \frac{1 - \alpha}{1 - \alpha^q} \tag{2.7}$$

from which (2.3) follows immediately.

3. A lower bound on the bandwidth

The sum rule (2.3) can be used to derive a lower bound on the total bandwidth at the critical point. For $\alpha = 1$, define

$$\mathcal{E}_\nu(k) \equiv \epsilon_\nu(k, k) = f_\nu(4 \cos kq) \tag{3.1}$$

then $\mathcal{E}_\nu(k)$ is a monotone function of k from the interval $[0, \pi/q]$ onto the ν th band. The width of this band is given by

$$S_\nu = \int_0^{\pi/q} \left| \frac{d\mathcal{E}_\nu(k)}{dk} \right| dk \tag{3.2}$$

and

$$\frac{d\mathcal{E}_\nu(k)}{dk} = - \frac{4q \sin kq}{P'_1(\mathcal{E}_\nu(k))}. \tag{3.3}$$

The function $1/|P'_1(E)|$ has a single minimum between every two zeros of $P'_1(E)$ and it is monotone above and below the extreme zeros of $P'_1(E)$. Therefore, it has a single minimum on each band (which may be at the edge of the band), and since $\mathcal{E}_\nu(k)$ is monotone, the function $1/|P'_1(\mathcal{E}_\nu(k))|$ (as a function of k in the interval $[0, \pi/q]$) has a single minimum for each band. Since the zeros $\{E_\nu\}$ of $P_1(E)$ correspond to $k = \pi/2q$ (i.e. $\mathcal{E}_\nu(\pi/2q) = E_\nu$), this implies that for each band, either for all $k \in [0, \pi/2q]$ (if the minimum occurs for $k \geq \pi/2q$), or for all $k \in [\pi/2q, \pi/q]$ (if the minimum occurs for $k \leq \pi/2q$), we have

$$\frac{1}{|P'_1(\mathcal{E}_\nu(k))|} \geq \frac{1}{|P'_1(E_\nu)|} \tag{3.4}$$

and thus (3.2) and (3.3) imply

$$S_\nu > \frac{4}{|P'_1(E_\nu)|}. \tag{3.5}$$

From (3.5) and the sum rule (2.3), we obtain

$$S > \frac{4}{q}. \tag{3.6}$$

4. Further implications for the total bandwidth

In this section we consider the implications of (2.3) for the total bandwidth in the limit $q \rightarrow \infty$. We start by making some remarks about the derivation of (1.2). This result is derived using a semiclassical (WKB) approximation, which assumes that β is small. The semiclassical analysis depends on the form of the Hamiltonian function corresponding to (1.1), which is (Azbel' 1964)

$$H(\hat{x}, \hat{p}) = 2 \cos \hat{p} + 2\alpha \cos \hat{x}. \tag{4.1}$$

When $\alpha = 1$, all the contours of the Hamiltonian function are closed curves, except for those at the separatrix energy, $E = 0$. The bandwidth is concentrated at the separatrix energy, because at other energies the width of the bands is determined by quantum mechanical tunnelling, which implies that the bandwidth is exponentially small in $1/\beta$ (Wilkinson 1984). The derivation of (1.2) (Thouless 1990, Watson 1991) depends on a detailed analysis of the behaviour of the wavefunction near the saddle points of the Hamiltonian function in phase space, where the quantum mechanical Hamiltonian can be approximated by a parabolic cylinder equation. In the region between the saddle points the solution is a standard WKB approximation and the form of the classical Hamiltonian function only enters via a phase integral, which plays no important role in the analysis. It is clear that if the result (1.2) holds for Harper's equation it will also hold for any other Hamiltonian $H(\hat{x}, \hat{p})$ in which the only open phase trajectory forms a simple lattice and in which the form of the Hamiltonian at the saddle points is alternately

$$\hat{H} \approx (\hat{p}^2 - \hat{x}^2) \quad \hat{H} \approx (\hat{x}^2 - \hat{p}^2). \tag{4.2}$$

provided that β is small.

Now we consider how the result (1.2), which is assumed to hold for small β (namely, for sequences $\beta_n \rightarrow 0$), can be extended to sequences $\beta_n \rightarrow \beta_0$ where $\beta_0 = p_0/q_0$ is any fixed rational. To this end we apply the results of (Wilkinson 1987), who considers the spectrum of an equation of the form of Harper's equation when β is very close to a rational number β_0 . In this case the spectrum can be divided into q_0 regions, each of which corresponds to the spectrum of an effective Hamiltonian $H_\nu(\hat{x}', \hat{p}')$. The effective Hamiltonian is periodic in \hat{x}' and \hat{p}' , and to lowest order in $\delta\beta \equiv \beta - \beta_0$ it corresponds to making the substitutions $k \rightarrow \hat{x}'/q_0$ and $\Delta \rightarrow \hat{p}'/q_0$ in the dispersion relation for the ν th band

$$\begin{aligned} H_\nu(\hat{x}', \hat{p}') &= \sum_{n,m=-\infty}^{\infty} A_{n,m} \exp[i(n\hat{x}' + m\hat{p}')] \\ &= \epsilon_\nu(\hat{x}'/q_0, \hat{p}'/q_0) + O(\delta\beta). \end{aligned} \tag{4.3}$$

The operators \hat{x}' and \hat{p}' satisfy the canonical commutation relation in the form

$$[\hat{x}', \hat{p}'] = 2\pi i\beta' \quad \beta' = \beta'_\nu = \frac{q_0\beta - p_0}{[(1 - q_0M_\nu)/p_0]\beta + M_\nu} \tag{4.4}$$

where M_ν is the Chern integer of the band, which can be identified with the quantised Hall-conductance integer of the ν th band in the case where Harper's equation represents a perturbed Landau level (Thouless *et al* 1982).

It follows from (2.2) that, if the higher order corrections in $\delta\beta$ are neglected, the effective Hamiltonian for the ν th band can be written as a function of the original Hamiltonian

$$\hat{H}_\nu(\hat{x}', \hat{p}') = f_\nu(2 \cos \hat{x}' + 2 \cos \hat{p}'). \tag{4.5}$$

The pattern of the separatrices is therefore the same as for the original Hamiltonian and the form of the Hamiltonian at the saddle points is

$$\hat{H}_\nu \approx f'_\nu(0)(\hat{p}'^2 - \hat{x}'^2) \quad \hat{H}_\nu \approx f'_\nu(0)(\hat{x}'^2 - \hat{p}'^2). \tag{4.6}$$

From (4.4) we see that $\beta'_\nu \rightarrow 0$ in the limit $\beta \rightarrow \beta_0$. We can therefore apply the result (1.2) to the effective Hamiltonian in this limit: the total bandwidth S_ν for this effective Hamiltonian will therefore obey

$$\lim_{\beta \rightarrow \beta_0} q_\nu S_\nu = |f'_\nu(0)| \frac{32C}{\pi} = \frac{1}{|P'_1(E_\nu)|} \frac{32C}{\pi} \tag{4.7}$$

where $\beta'_\nu = p_\nu/q_\nu$. The exact value of q_ν depends on the Hall-conductance integer of the band, but in the limit $\delta\beta \rightarrow 0$

$$q_\nu/q \rightarrow 1/q_0 \tag{4.8}$$

and thus the total bandwidth satisfies

$$\lim_{q \rightarrow \infty} qS = \frac{32C}{\pi} \tag{4.9}$$

which is the same as (1.2).

This result shows that if the Thouless conjecture (1.2) can be proved to be valid for all sequences $\beta_n \rightarrow 0$, then it should be valid for (at least sufficiently rapidly converging) sequences $\beta_n = p_n/q_n \rightarrow p_0/q_0$. Although the possible limiting values p_0/q_0 form a dense set, our results do not immediately imply that the result is true for all sequences with $q_n \rightarrow \infty$.

5. Numerical illustrations

In this section we illustrate the formulae (4.3) and (4.4) for the effective Hamiltonian describing the splitting of a band, and the result (4.7) relating the measure contained in the ν th cluster of bands to the derivative $P'_1(E_\nu)$.

To apply (4.4) we first need to identify the Hall-conductance integers of the bands. This can be achieved using the gap labelling theorem (Simon 1982), which states that the fraction μ of the integrated density of states below a given gap can be written as

$$\mu_{n,m} = n\beta + m \tag{5.1}$$

where n and m are integers. It follows from the Strěda formula (Strěda 1982) that the integer m is the Hall-conductance integer for the states below the gap. The Hall-conductance integer of the ν th band can be obtained by taking the difference of the values of m for the adjacent gaps. Unfortunately we cannot use this result

immediately because when $\beta = p_0/q_0$ is rational the labelling is ambiguous (μ is unchanged if we take $n \rightarrow n + q_0, m \rightarrow m - p_0$). Instead we use a physical argument to determine the integers. In the limit $\alpha \rightarrow 0$ the integer n is related to the size of the gap: $\Delta E = O(\alpha^n)$, i.e. the gap first opens at the n th order of perturbation theory. When α is small we expect the gaps to open at the lowest possible value of n consistent with (5.1). A result of van Mouche (1989) shows that the gaps of Harper's equation remain open for all values of α (apart from the closed gap at $E = 0$ for even q required by symmetry of the spectrum about $E = 0$). This shows that the labelling at $\alpha = 1$ is the same as at small α . For example, when $\beta_0 = 3/7$, these considerations enable us to identify the gap labelling integers for the eight gaps as $(0, 0), (-2, 1), (3, -1), (1, 0), (-1, 1), (-3, 2), (2, 0), (0, 1)$, and the values of M_ν are respectively $1, -2, 1, 1, 1, -2, 1$.

In order to illustrate (4.3) and (4.4) we considered an effective Hamiltonian in the form of a cosine Fourier expansion

$$H_\nu(\hat{x}', \hat{p}') = \sum_{n,m} a_{n,m} \cos(n\hat{x}' + m\hat{p}') \quad (5.2)$$

with $[\hat{x}', \hat{p}'] = 2\pi i\beta'$ given by (4.4) and with the coefficients constrained so that $H_\nu(\hat{x}', \hat{p}')$ has all of the symmetries of the original Hamiltonian (4.1). When $\alpha = 1$, these symmetries are four-fold rotational symmetry, implying $a_{m,-n} = a_{n,m}$ and mirror symmetry, implying $a_{n,m} = a_{m,n}$. We used a least-squares program to vary the independent coefficients $a_{n,m}$ so that the edges of the bands of $H_\nu(\hat{x}', \hat{p}')$ would agree as closely as possible with the edges of the appropriate cluster of subbands of the spectrum of Harper's equation: a finite number of coefficients $a_{n,m}$ were varied, with $n = 0, \dots, N_c, m = 0, \dots, n$. The residue of the least-squares fit, defined as the sum of the squares of the deviations of the band edges from their target values, was found to approach zero rapidly as N_c was increased.

Figure 1(a) and (b) illustrate the correspondence between the spectrum of the least-squares fitted H_ν and a subset of the spectrum of Harper's equation. The top row in each of these figures is the full spectrum of Harper's equation for $\beta = 314/727$, which is close to the low order rational $\beta_0 = 3/7$. When $\beta = 3/7$ the spectrum consists of seven bands, of which the second and sixth have Chern integer $M_\nu = -2$ and the remainder have $M_\nu = 1$. Correspondingly, the bands of Harper's equation for $\beta = 314/727$ form seven clusters. In figure 1(a) the structure of the second cluster (bands 100 to 215) is magnified (centre row), and compared with the spectrum of an effective Hamiltonian of the form (5.2), with $\beta'_2 = 17/116$ (obtained from (4.4)). Similarly, in figure 1(b) the spectrum of the third cluster (bands 216 to 314) is compared with an effective Hamiltonian with $\beta'_3 = 17/99$. In each case the Fourier expansion used for the least-squares fit included coefficients up to $N_c = 5$ and an excellent fit of the spectrum is obtained.

According to (4.3), in the limit $\beta \rightarrow p_0/q_0$ the Fourier coefficients $a_{n,m}$ of the effective Hamiltonian should tend towards those of the dispersion relation of the ν th band defined by

$$\epsilon_\nu(k, \Delta) = \sum_{n,m} b_{n,m} \cos[(nk + m\Delta)q_0]. \quad (5.3)$$

The Fourier coefficients $a_{n,m}$ of the effective Hamiltonian were determined numerically for a sequence of rational β approaching $\beta_0 = 1/3$, for the first band of the

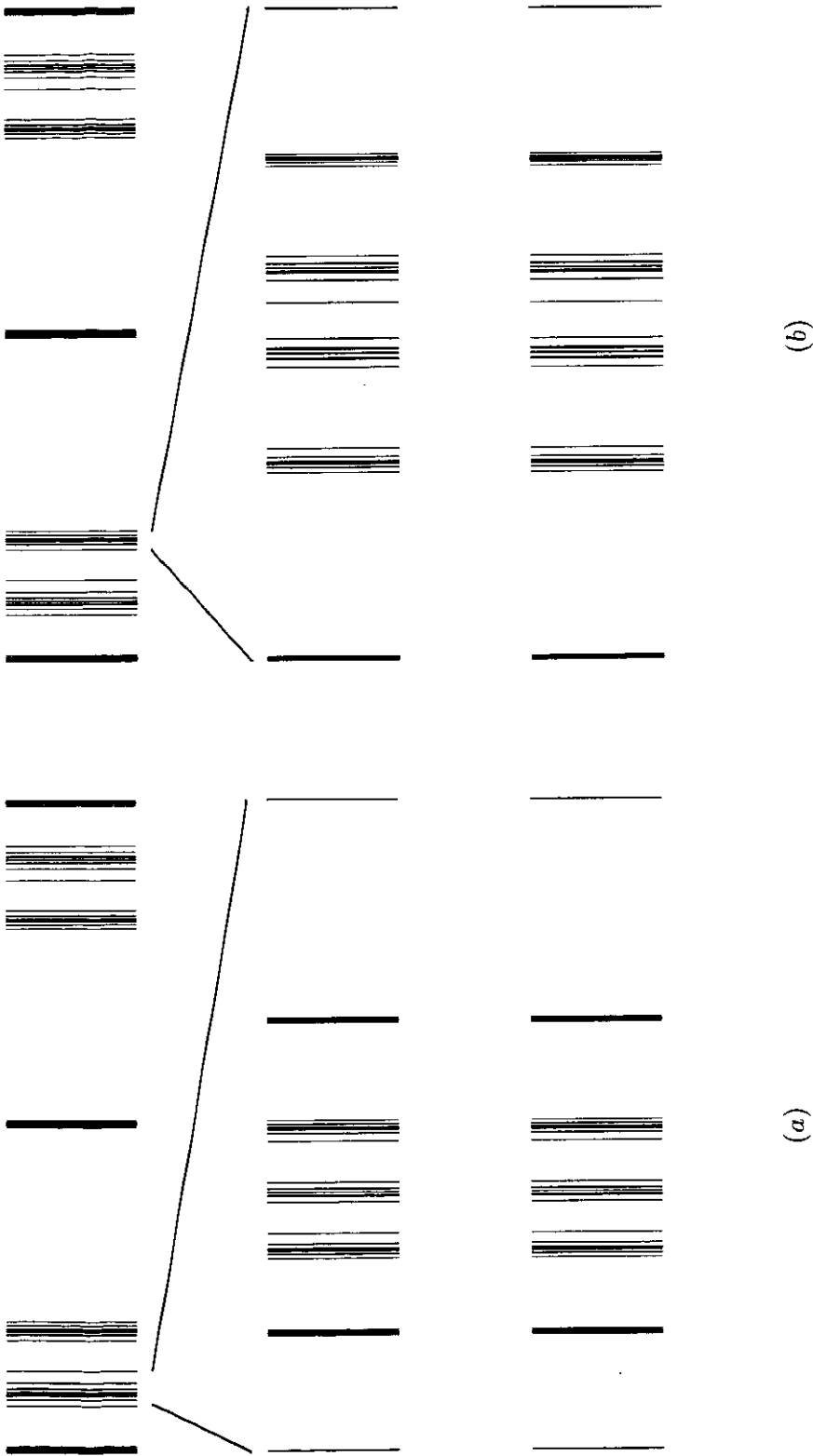

Figure 1. Comparison of the full spectrum of Harper's equation for $\beta = 314/727$ (top row), with the spectrum of an effective Hamiltonian (bottom row) chosen to match the spectrum of the second cluster of bands (centre row). The band has Hall-conductance integer $M_2 = -2$, implying that the effective Hamiltonian has commensurability $\beta'_2 = 17/116$. (a) As case (a), for the third cluster of bands: here $M_3 = 1$, $\beta'_3 = 17/99$.

spectrum. The results are shown in table 1. The Fourier coefficients $a_{0,0}$, $a_{1,0}$ approach the limiting values $b_{0,0}$, $b_{1,0}$ quoted in the last column. The $a_{1,1}$ and $a_{2,0}$ coefficients do not approach the limiting value, but the linear combination $2a_{1,1} + a_{2,0}$ does approach the expected limit. The reason for this behaviour is that the fit of the expansion coefficients $a_{n,m}$ to the spectrum is ill-conditioned. An explanation for the invariance of the combination $2a_{1,1} + a_{2,0}$ is given in the appendix. The data shows that the limiting values are approached linearly as a function of $\delta\beta \equiv \beta - \beta_0$, to within numerical uncertainties, confirming the estimate for the error term in (4.3).

Table 1. Fourier coefficients of the effective Hamiltonian for a sequence of rational β approaching $\beta_0 = 1/3$. The coefficients in the last column are those of the Fourier expansion of the dispersion relation.

β	50/149	99/295	102/307	200/601	1/3
$a_{0,0}$	-2.422 970	-2.422 893	-2.434 221	-2.432 422	-2.430 548
$a_{1,0}$	0.089 753	0.089 840	0.086 400	0.086 921	0.087 512
$a_{1,1}$	0.011 806	0.010 914	0.009 668	0.010 041	0.009 834
$a_{2,0}$	0.003 343	0.005 135	0.004 474	0.004 254	0.005 169
$a_{2,0} + 2a_{1,1}$	0.027 039	0.026 963	0.023 810	0.024 337	0.024 836

We also performed some numerical tests of the formula (4.7) for the total bandwidths of the seven clusters of bands for a sequence of rationals approaching $3/7$. The results are summarized in table 2, which lists the fraction $\lambda_\nu = S_\nu/S$ of the weight of the spectrum in each of the first four bands (the weights of the other bands can be obtained from the symmetry of the spectrum about $E = 0$). The limiting values as $\beta \rightarrow \beta_0$ are given by $q_0/|P'_1(E_\nu)|$, which is tabulated in the last column. The table also lists the Thouless number $T = qS$ and the mean absolute fractional deviation δ of the weights λ_ν from their limiting values. The deviation δ decreases as $\beta \rightarrow \beta_0$, but the decrease is not monotonic: the deviation is anomalously large when β'_ν is of the form $1/q_\nu$. This is presumably related to the fact that the convergence of qS is slowest when $p = 1$ (Thouless and Tan 1991a). The deviations of qS from the limiting value $32C/\pi$ were discussed by Thouless and Tan (1991b): our results confirm their prediction that the deviation is larger when $q_0p - p_0q$ is odd.

Table 2. Fractional weights $\lambda_\nu = S_\nu/S$ of the four lowest clusters of bands, for a sequence of rational β approaching $\beta_0 = 3/7$. The data in the last column is the limiting values predicted from (4.7); δ is a measure of the average fractional deviation from these limiting values.

β	302/705	1 053/2 456	1 723/4 021	3 433/8 011	3 848/8 979	3/7
λ_1	0.065 021	0.065 037	0.065 438	0.065 350	0.064 917	0.065 260
λ_2	0.210 149	0.209 090	0.208 277	0.208 473	0.209 923	0.208 670
λ_3	0.183 597	0.184 673	0.184 812	0.184 776	0.184 057	0.184 740
λ_4	0.082 467	0.082 401	0.082 947	0.082 804	0.082 205	0.082 659
δ	4.82×10^{-3}	2.23×10^{-3}	2.12×10^{-3}	1.07×10^{-3}	5.12×10^{-3}	—
$ \beta - \beta_0 $	2.03×10^{-4}	1.75×10^{-4}	7.11×10^{-5}	3.57×10^{-5}	1.59×10^{-5}	—
qS	9.325 255	9.331 060	9.329 949	9.329 953	9.327 532	$32C/\pi$

Acknowledgment

M W acknowledges considerable help with the numerical work from E J Austin and the hospitality of the Technion during his visit. The award of research grants by the UK Science and Engineering Research Council and the University of Strathclyde is gratefully acknowledged. Y L would like to thank J Avron for useful discussions. This work is partially supported by the US-Israel BSF.

Appendix

The fitting of the Fourier coefficients of the effective Hamiltonian (5.2) to the spectrum of a subband is ill-conditioned. It is possible to make unitary transformations of the effective Hamiltonian (4.3) which leave its form unchanged: the Hamiltonian remains in the form of a Fourier expansion, but with different coefficients. In this appendix we examine the effect of these unitary transformations on the Fourier coefficients $a_{n,m}$, in the limit $\beta \rightarrow \beta_0$. Consideration of (4.4) shows that this is a semiclassical ($\hbar \rightarrow 0$) limit and it is therefore most convenient to consider the corresponding classical transformation, which is a canonical transformation $(x, p) \rightarrow (x', p')$.

In the limit $\hbar \rightarrow 0$, a canonical transformation of the Hamiltonian $H(x, p)$ changes its spectrum by $O(\hbar^2)$. The canonical transformation can therefore be considered to be a good approximation to a unitary transformation, which leaves the spectrum unchanged. The set of canonical transformations we must consider are those which leave the Hamiltonian in the form of a 2π -periodic function of x and p , with four-fold and mirror symmetries. Such a canonical transformation maps the set of lines illustrated in figure 2 into itself. The canonical transformations required are generated by the action of a Hamiltonian $\mathcal{H}(x, p)$ for which this set of lines is a level surface. This Hamiltonian can be expanded as follows:

$$\mathcal{H}(x, p) = \sum_{n=0}^{\infty} \sum_{m=0}^{n-1} c_{n,m} [\sin(n\pi x) \sin(m\pi p) - \sin(m\pi x) \sin(n\pi p)]. \tag{A1}$$

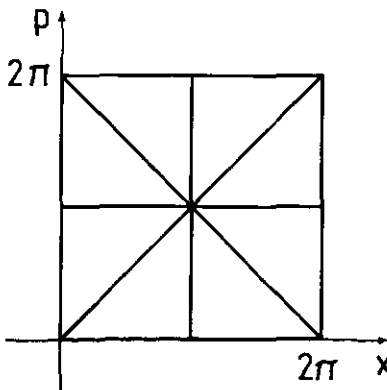

Figure 2. Canonical transformations which leave the Hamiltonian in the form of a Fourier series, with fourfold and mirror symmetries, map this set of lines into itself. This is therefore a level set of the generating Hamiltonian $\mathcal{H}(x, p)$.

The action of this Hamiltonian over a short time $\delta\tau$ generates a canonical transformation of the form

$$x \rightarrow x' = x + \frac{\partial \mathcal{H}}{\partial p} \delta\tau \quad p \rightarrow p' = p - \frac{\partial \mathcal{H}}{\partial x} \delta\tau \tag{A2}$$

which transforms the original Hamiltonian $H(x, p)$ as follows:

$$H(x, p) \rightarrow H'(x, p) = H(x', p') = H(x, p) + \{H, \mathcal{H}\} \delta\tau \tag{A3}$$

where $\{.,.\}$ denotes a Poisson bracket.

To a good approximation, the higher order Fourier coefficients of $H(x, p)$ in (4.3) are usually very small compared to the $(1, 0)$ coefficient. Consider the effect of the canonical transformation generated by the $c_{2,1}$ term in the expansion (A1) on the Hamiltonian $H(x, p) = \cos x + \cos p$: using (A3)

$$H'(x, p) = \cos x + \cos p + \delta\tau \left[\frac{1}{2} \cos(x + p) + \frac{1}{2} \cos(x - p) - \cos 2x - \cos 2p - \frac{1}{4} \cos(x + 3p) - \frac{1}{4} \cos(x - 3p) - \frac{1}{4} \cos(3x + p) - \frac{1}{4} \cos(3x - p) + \cos(2x + 2p) + \cos(2x - 2p) \right]. \tag{A4}$$

Table 3. Illustrating the ill-conditioned nature of the Fourier expansion used to fit the spectrum: the first perturbation is nearly isospectral, in agreement with the analysis presented in the appendix.

Perturbation	Residue
None	2.3×10^{-7}
$\frac{1}{2}(1, 1) - \frac{1}{4}(3, 1) - (2, 0) + (2, 2)$	1.2×10^{-6}
$\frac{1}{2}(1, 1) - \frac{1}{4}(3, 1) - (2, 0)$	7.8×10^{-4}
$\frac{1}{2}(1, 1) - \frac{1}{4}(3, 1) + (2, 2)$	6.7×10^{-4}
$\frac{1}{2}(1, 1) - (2, 0) + (2, 2)$	1.2×10^{-4}
$-\frac{1}{4}(3, 1) - (2, 0) + (2, 2)$	3.6×10^{-4}

This result shows that the spectrum will be insensitive to perturbing the Fourier coefficients $a_{1,1}, a_{2,0}, a_{3,1}, a_{2,2}$ (and the others related by symmetry) respectively by the following multiples of a small number $\delta\tau$: $\frac{1}{2}, -1, -\frac{1}{4}, 1$. Table 3 shows the effect of adding this perturbation, which is symbolized by the notation $\frac{1}{2}(1, 1) - (2, 0) - \frac{1}{4}(3, 1) + (2, 2)$, with a multiplier $\delta\tau = 10^{-3}$. The residue of the least-squares fit increases by a much smaller amount than for other comparable perturbations. The example here used $\beta = 200/601, \beta_0 = 1/3$, fitting the first cluster of bands (1 to 200) using coefficients up to $N_c = 5$.

It is easy to confirm that the contribution to (A1) with Fourier coefficient $c_{n,m}$ causes a nearly isospectral perturbation of the Hamiltonian $H(x, p) = \cos x + \cos p$ with Fourier coefficients $(n-1, m), (n+1, m), (n, m-1), (n, m+1)$. It is therefore clear that, within the approximations used, the only term in (A1) which affects the $a_{1,1}$ and the $a_{2,0}$ coefficients of $H(x, p)$ is the term with coefficient $c_{2,1}$. It follows from the isospectral perturbation (A4) that the sum of the coefficients $2a_{1,1} + a_{2,0}$

is a canonical invariant, for small $\delta\tau$. This conclusion is confirmed by the data in table 1. Invariants involving other combinations of coefficients can be obtained by the same method.

References

- Abramowitz M and Stegun I A 1972 *Handbook of Mathematical Functions* 4th edn (New York: Dover) pp 807
- Avron J E, van Mouche P and Simon B 1990 *Commun. Math. Phys.* **132** 103–18
- Azbel M Ya 1964 *Zh. Eksp. Teor. Fiz.* **46** 929 (Engl. transl. *Sov. Phys.-JETP* **19** 634–45)
- Bellissard J and Simon B 1982 *J. Funct. Anal.* **48** 408–19
- Harper P G 1955 *Proc. Phys. Soc. A* **68** 879–92
- Hofstadter D R 1976 *Phys. Rev. B* **14** 2239–49
- Rauh A 1974 *Phys. Status Solidi B* **65** 131–5
- 1975 *Phys. Status Solidi* **1975 B** **69** 9–13
- Simon B 1982 *Adv. Appl. Math.* **3** 463–90
- Strěda P 1982 *J. Phys. C* **15** L717–27
- Thouless D J 1983 *Phys. Rev. B* **27** 6083–7
- 1990 *Commun. Math. Phys.* **127** 187–93
- Thouless D J, Kohmoto M, Nightingale M P and den Nijs M 1982 *Phys. Rev. Lett.* **49** 405–8 1982
- Thouless D J and Tan Y 1991a *J. Phys. A: Math. Gen.* **24** 4055–66
- 1991b *Physica* **177A** 567–77
- van Mouche P 1989 *Commun. Math. Phys.* **122** 23–34
- Watson G I 1991 *J. Phys. A: Math. Gen.* **24** 4999–5010
- Wilkinson M 1987 *J. Phys. A: Math. Gen.* **20** 4337–54
- 1984 *Proc. R. Soc. A* **391** 305–50