

A Difference That Makes a Difference  
Milton Keynes, 7-9 September 2011

# **Modeling Cultural Evolution** **through a Holographic Information Model**

Ambjörn Naeve

Knowledge Management Research Group  
Royal Institute of Technology,  
Uppsala University  
Stockholm University

<http://kmr.csc.kth.se/wp>

# What is a model?

A model is a representation of structure

[David Hestenes]

# Basic properties of a model

A model is created:

- within a **context**
- for a **purpose**
- with respect to a **target group**

The models I will discuss have been created:

- within the **context of human communication**
- for the **purpose of creating 'placeholders' for describing and discussing cultural evolution**
- with respect to the **target group of the interested public**

# Mental Models

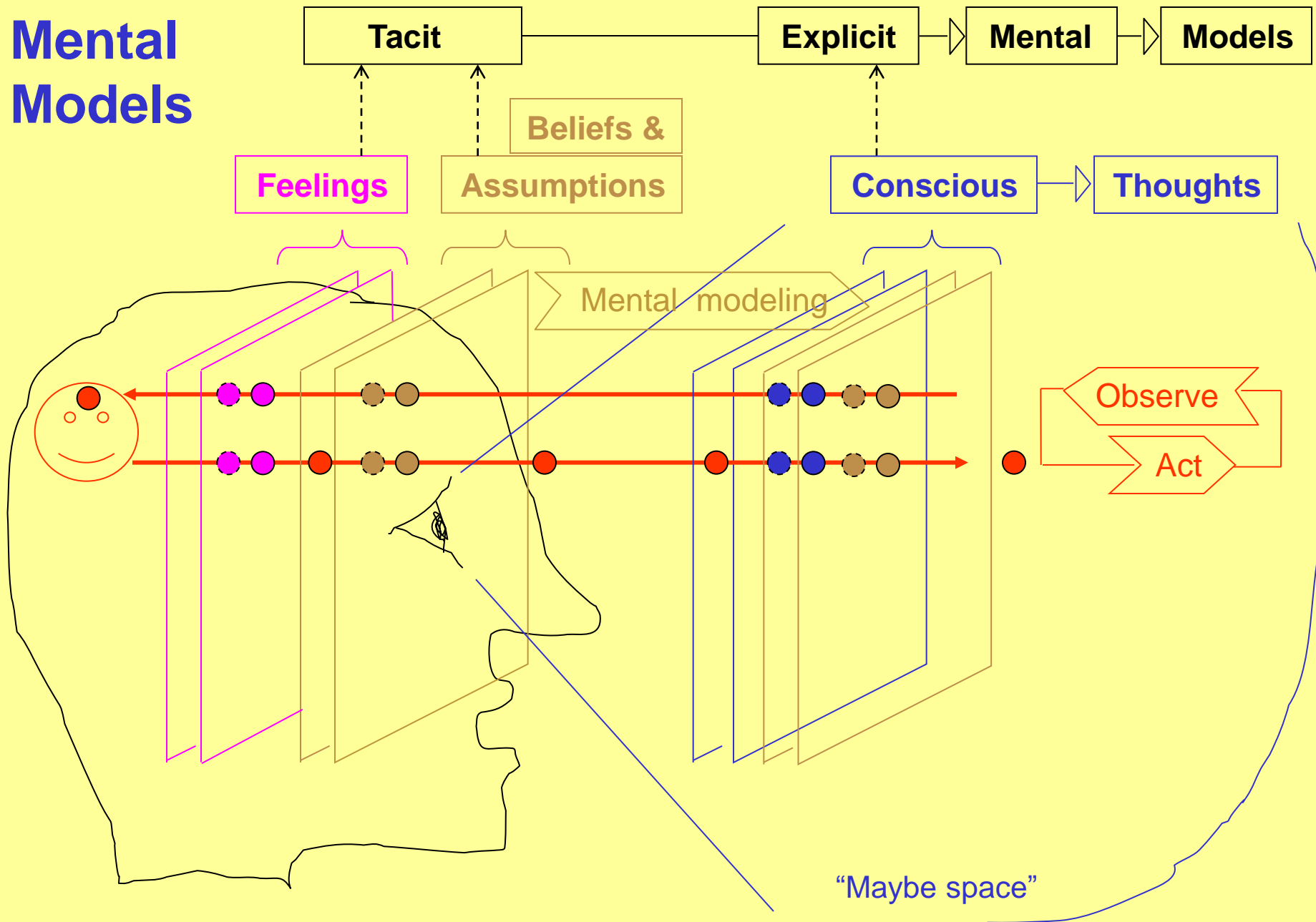

# Inter- and Intra Group Communication

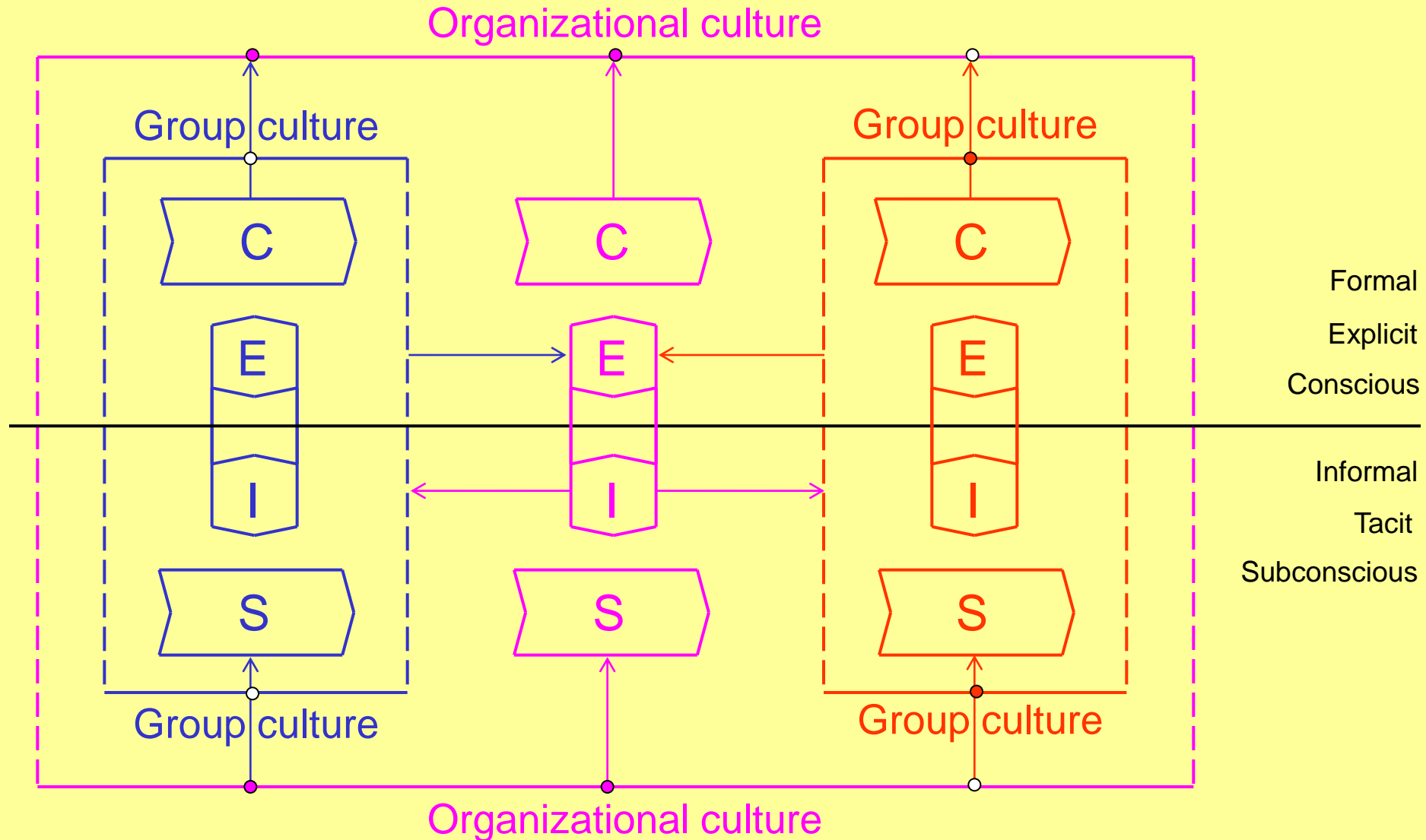

# Notational Simplification

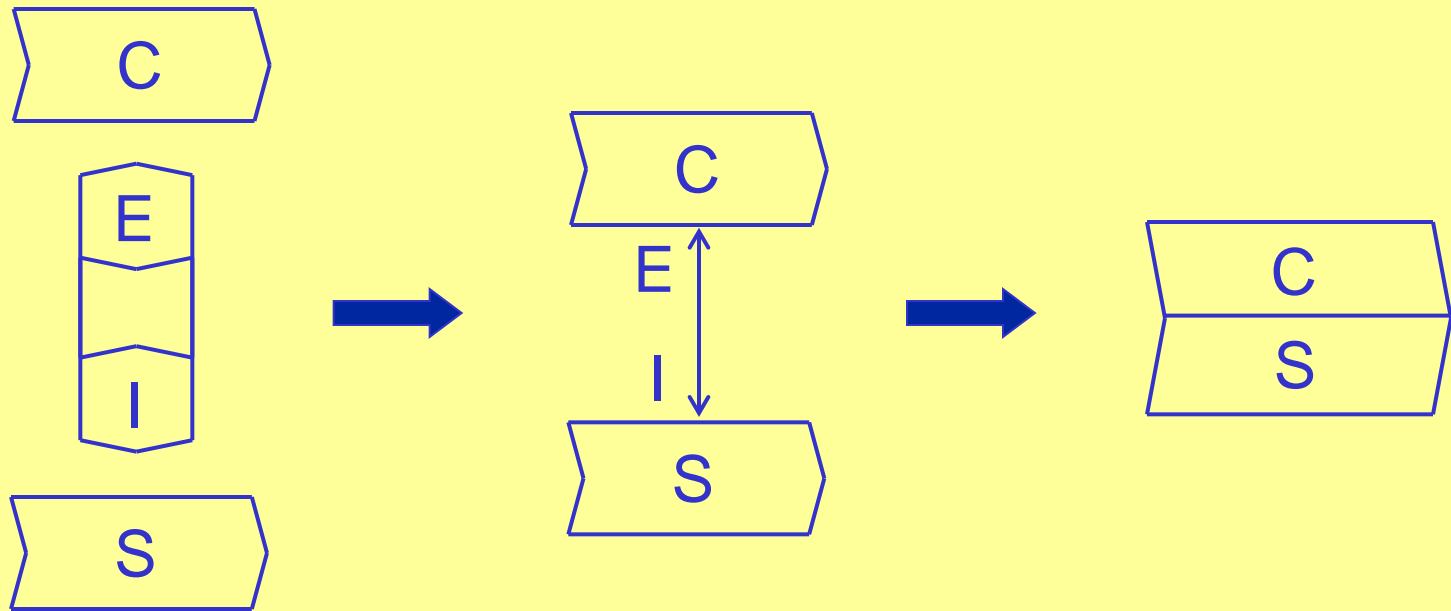

# Explicit/Tacit Process @ work

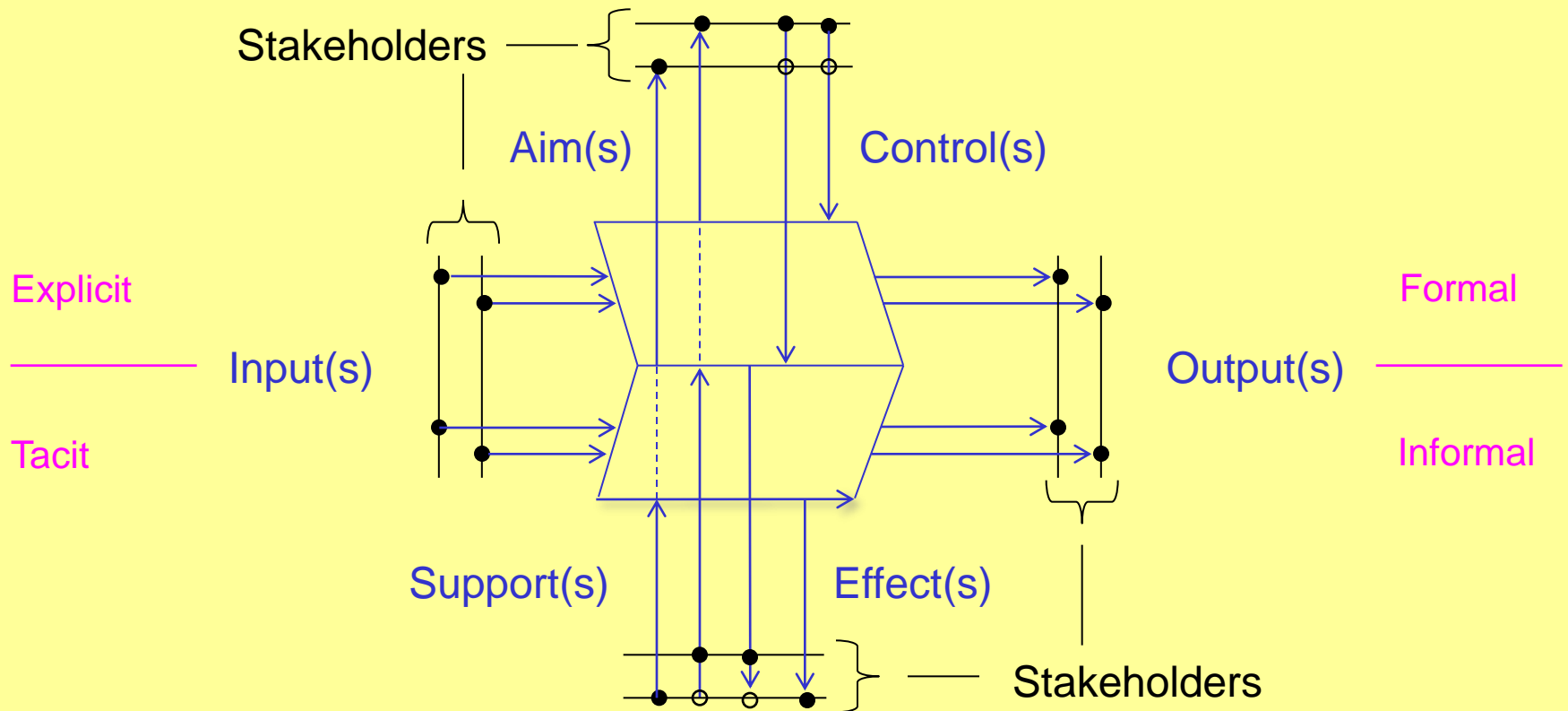

Naeve, A., et al. (2007), *A SECI-based Framework for Professional Learning Processes*, PROLEARN Deliverable D1.10, July 2007, <http://tinyurl.com/38grfjq>

# The interference pattern of two circular waves

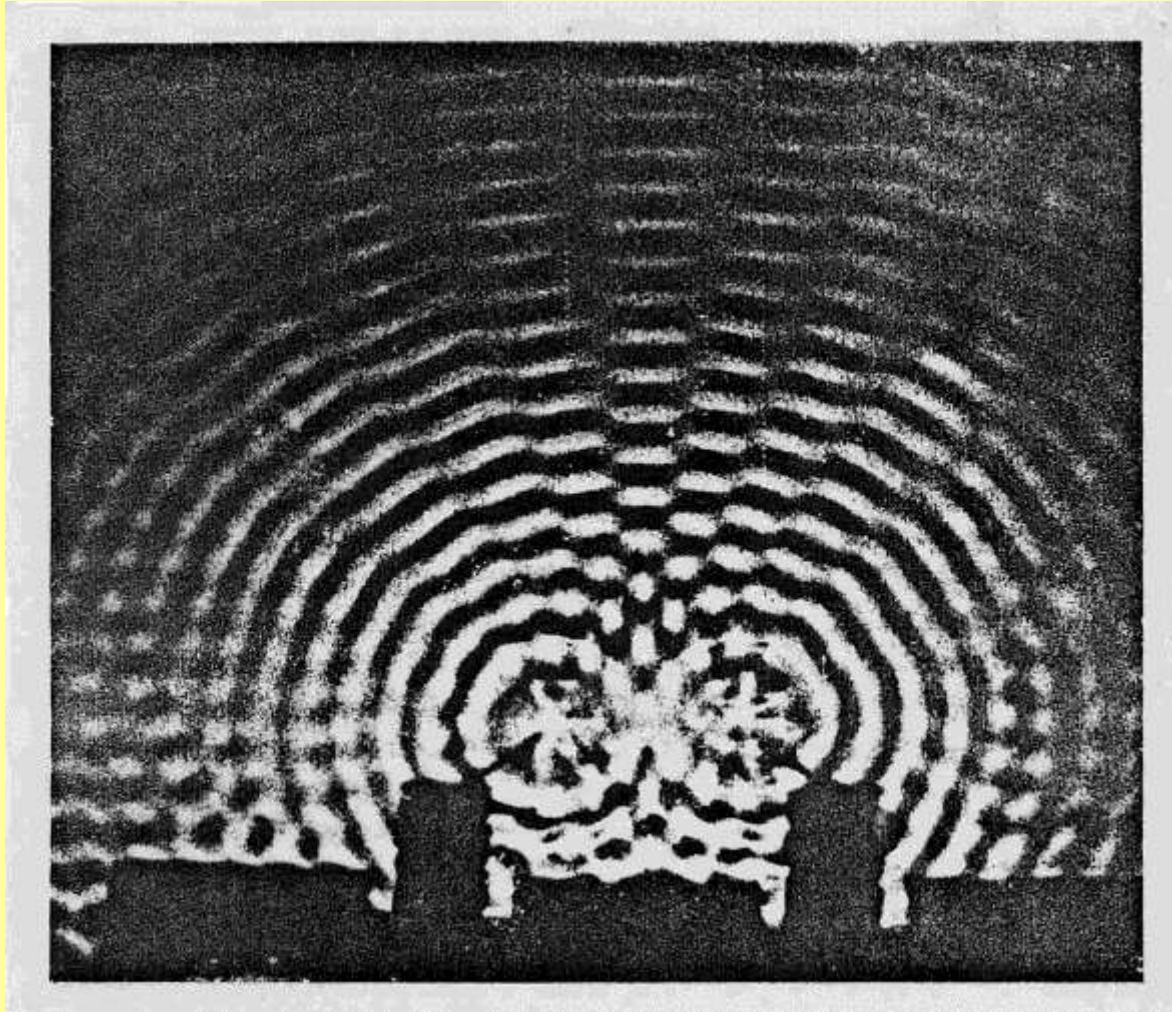



# The basic holographic setup

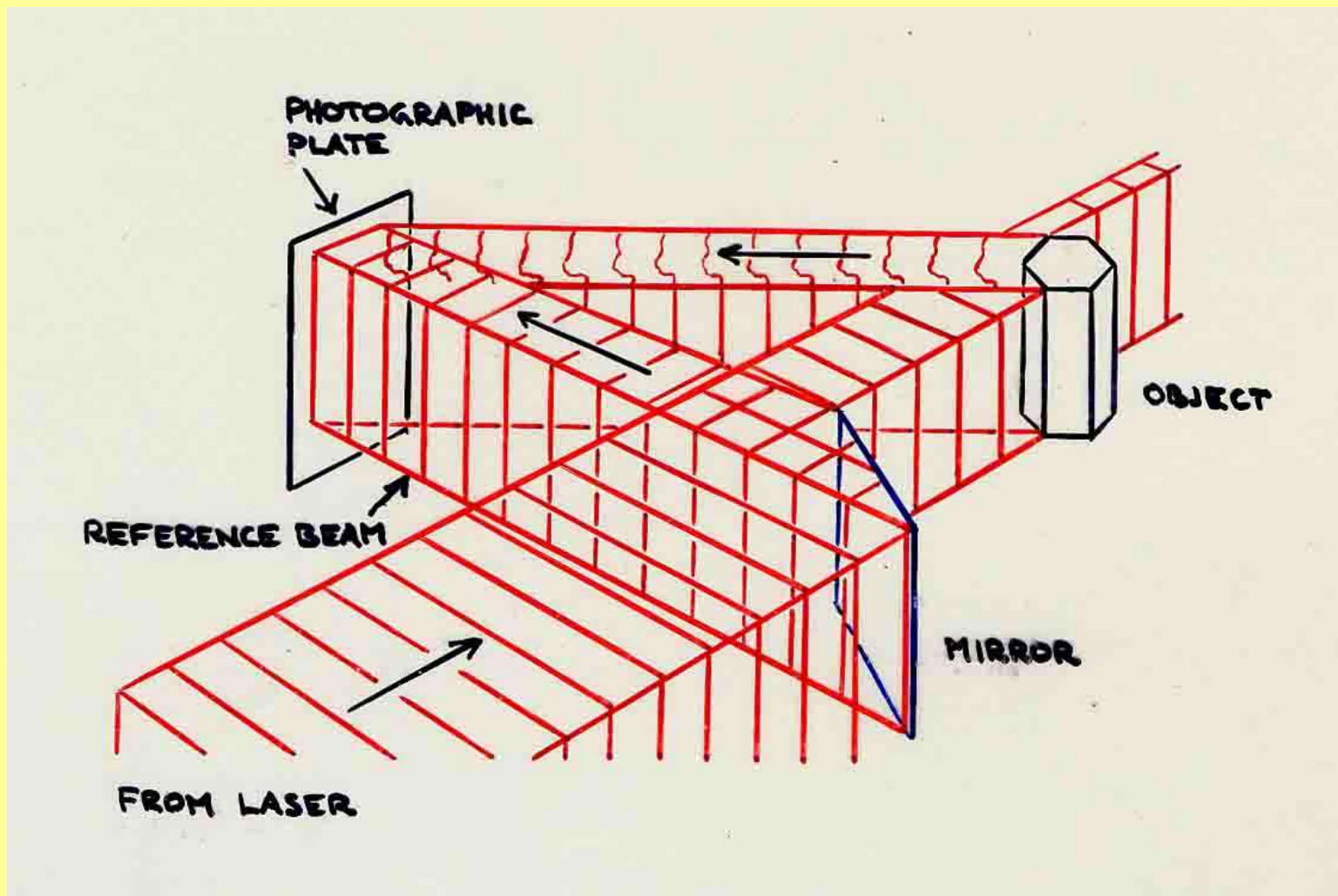

# Perceiving objects through concepts

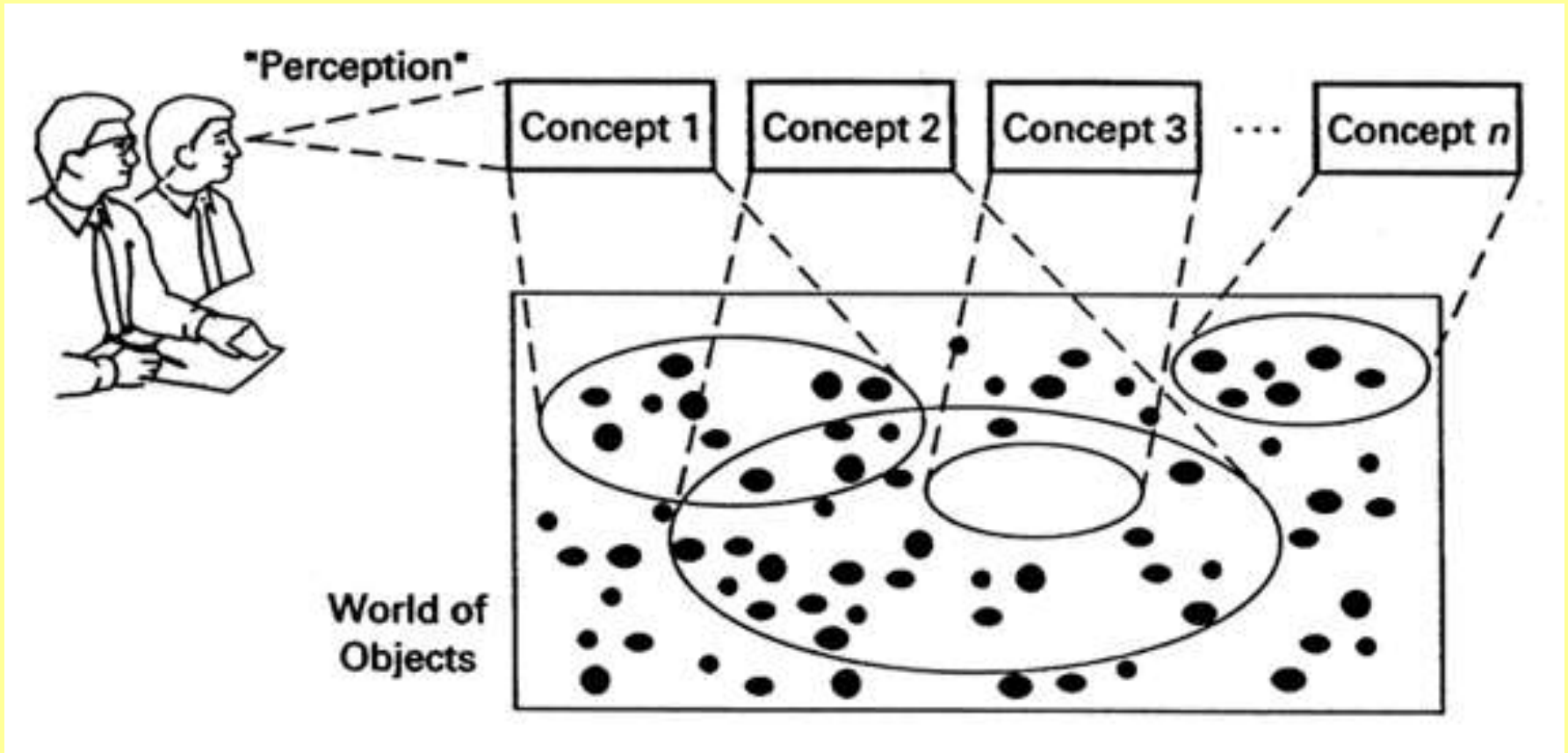

# Assigning Situated Significance to Aspects

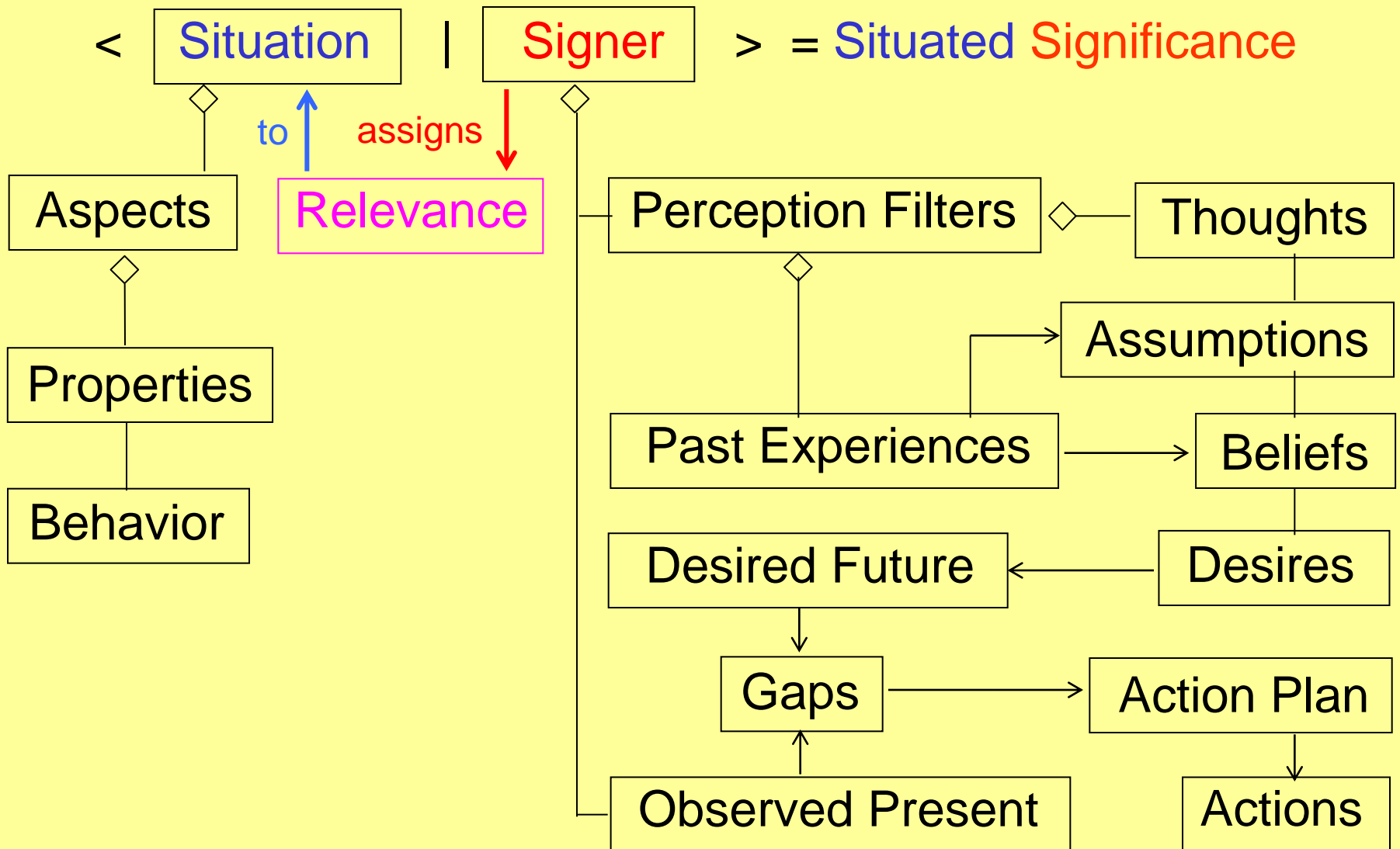

# Interpreting an Object through a Model

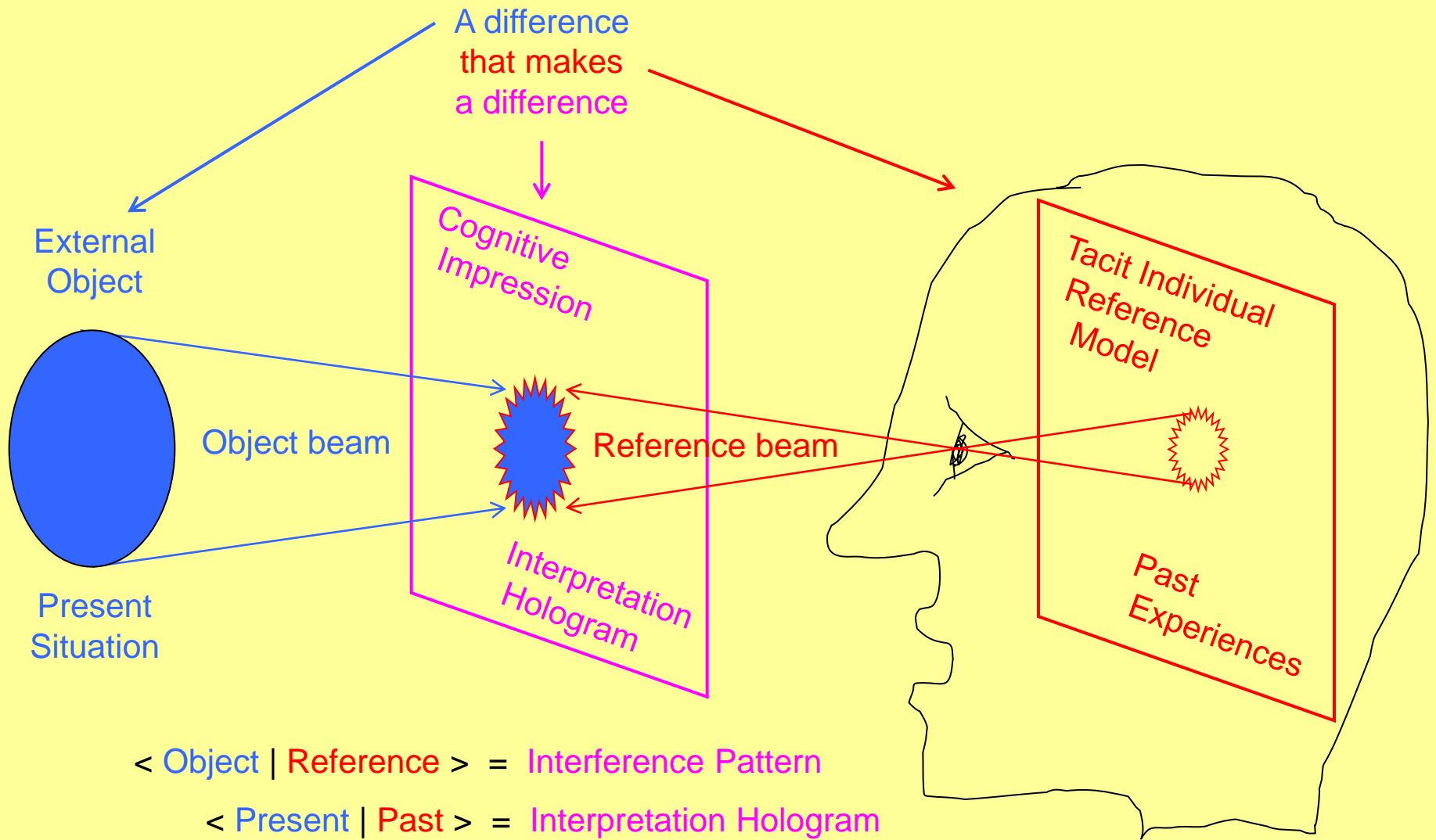

# Evolving a Cultural Reference Model

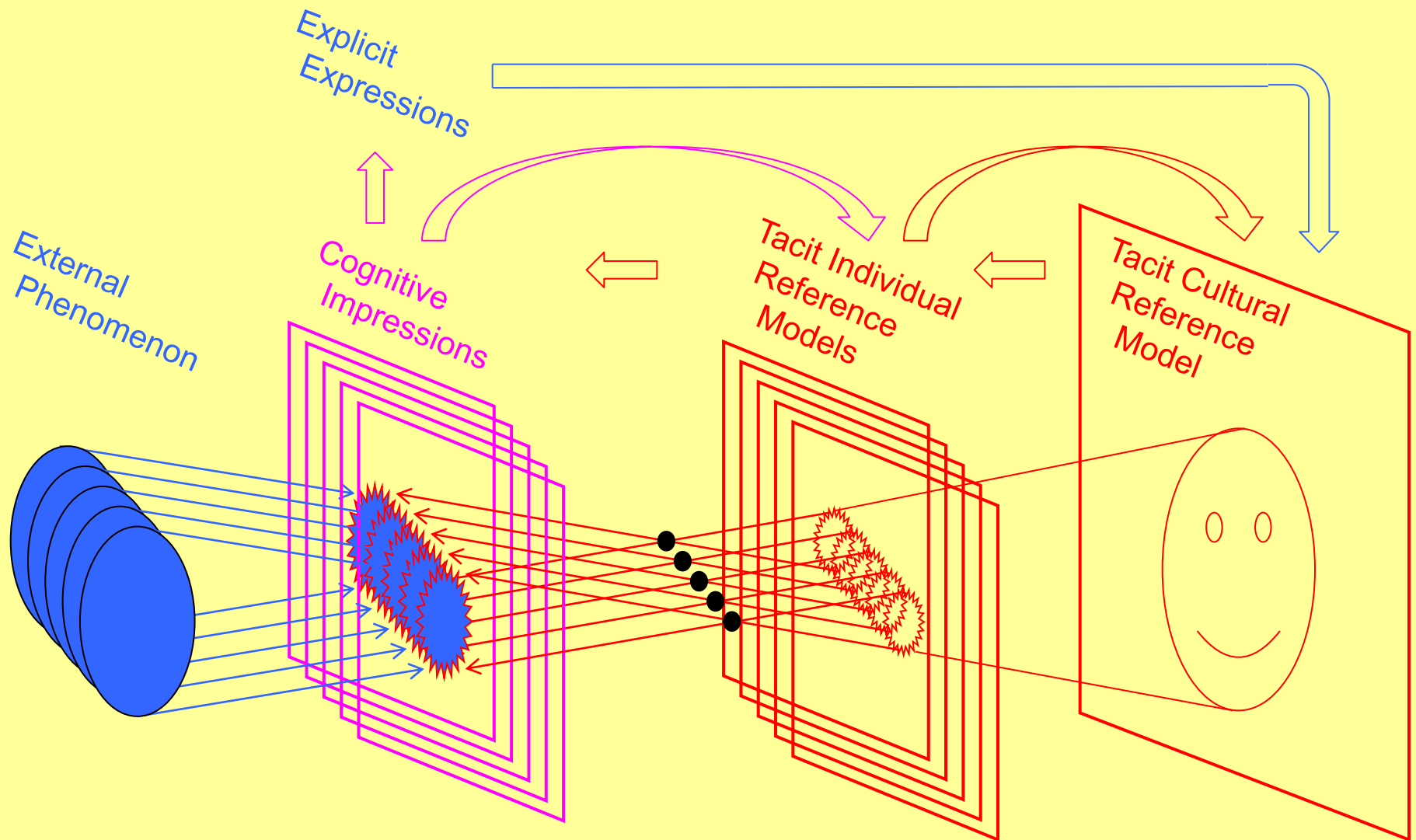

Hologram = Interference pattern

< Situation | Filter > = Relevance

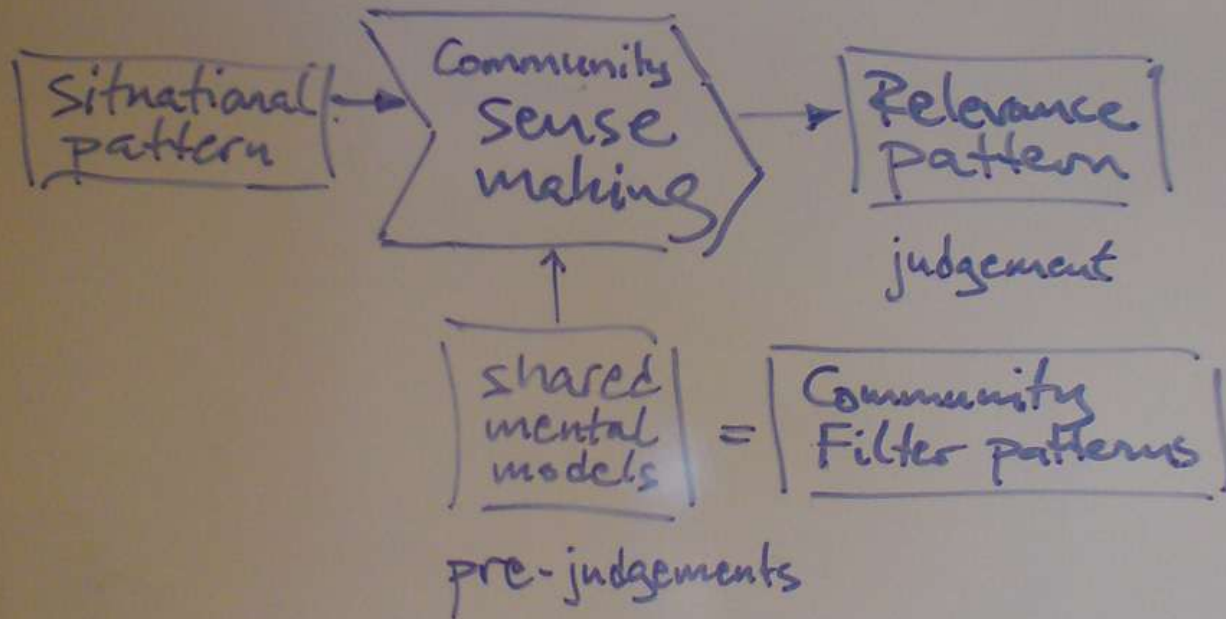

# Storing Im- and Ex-pressed Situations

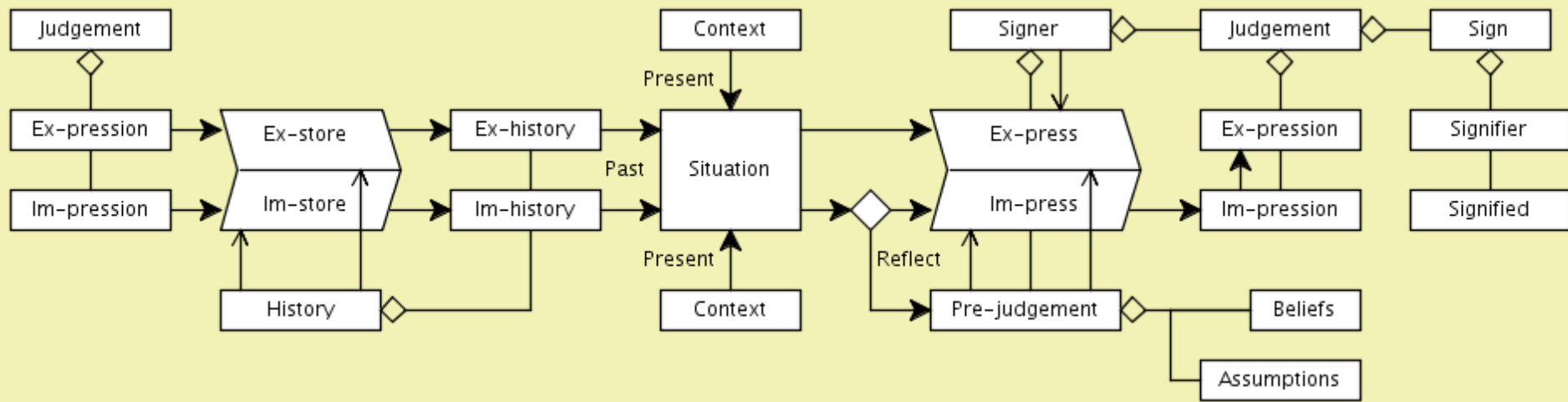

FLOW = NOW = STORY

STORE = THEN = HISTORY =  $\int$  STORY

< Situation | Pre-judgement > = Judgement = Im-pression

< Im-pression | Externalize > = Ex-pression

# Cultural translation by the living and the dead

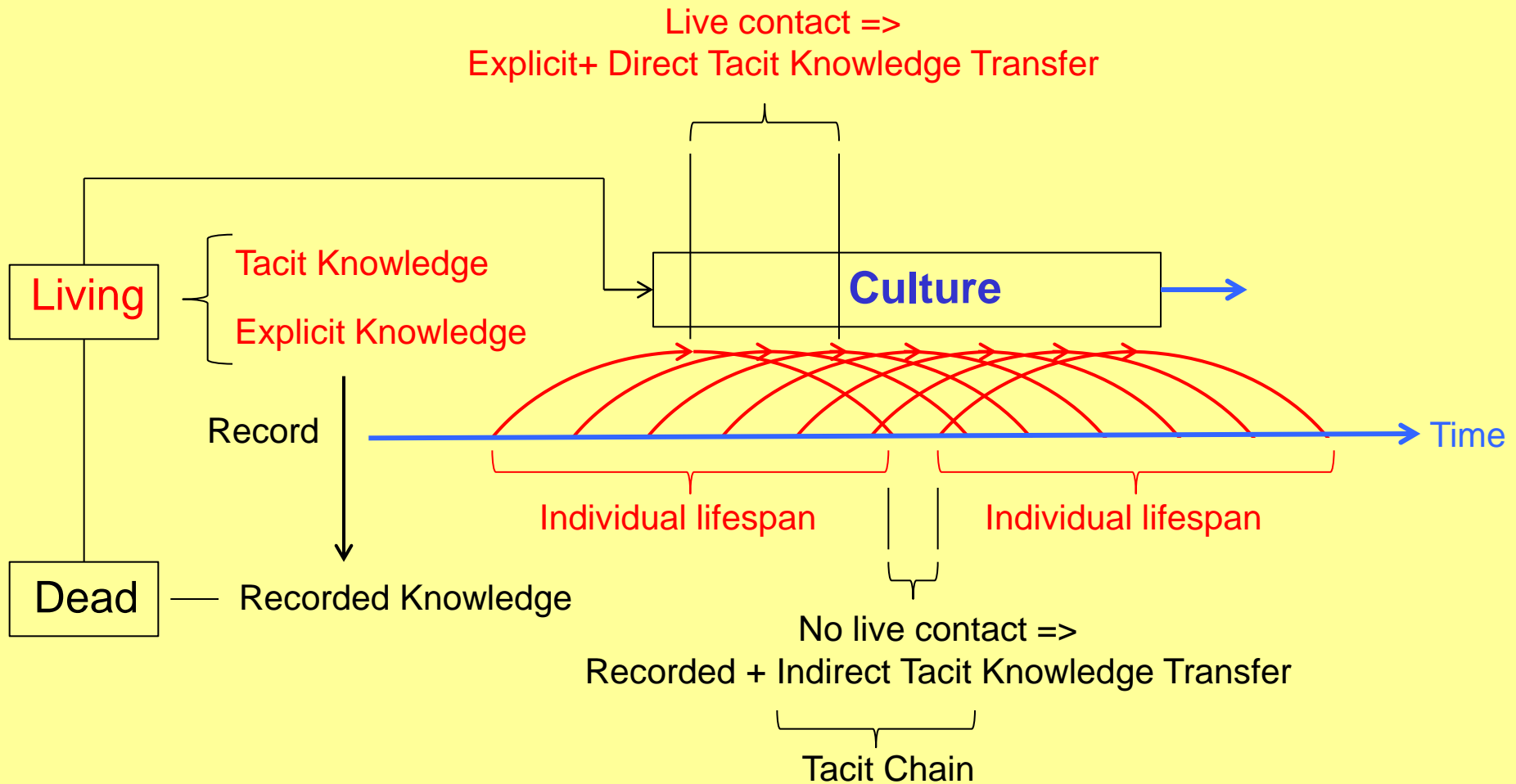



# Recorded and Tacit Knowledge Transfer

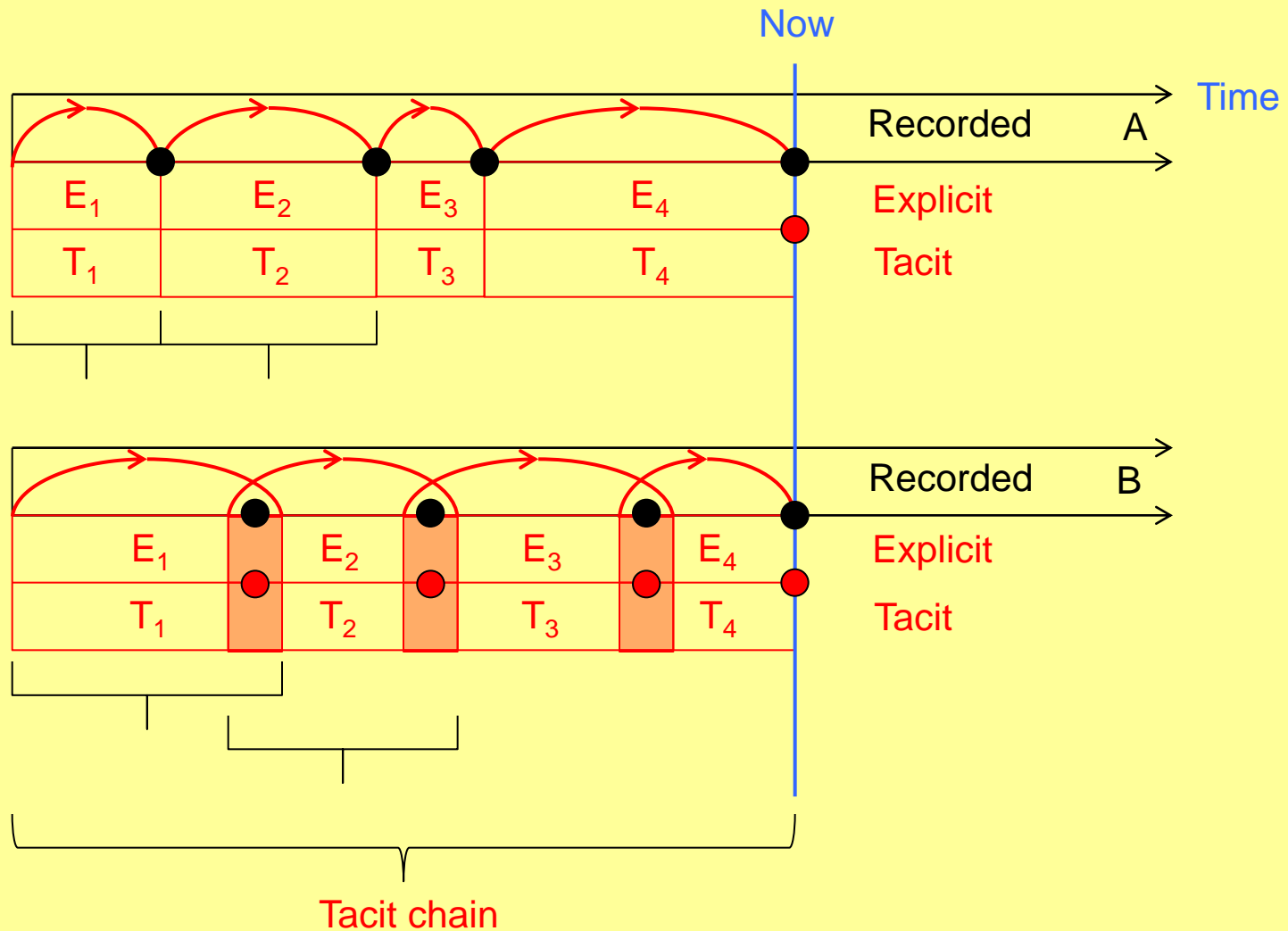

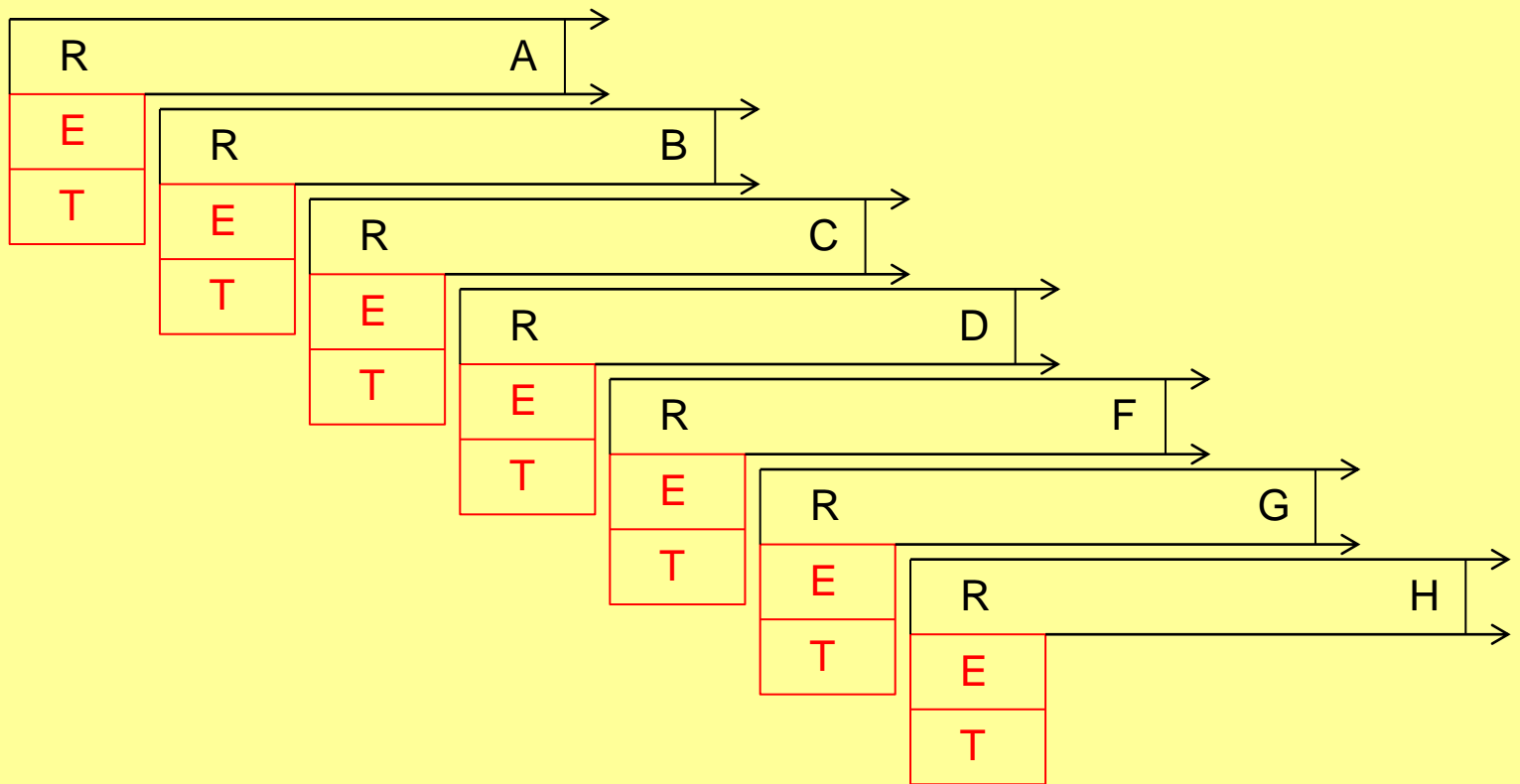

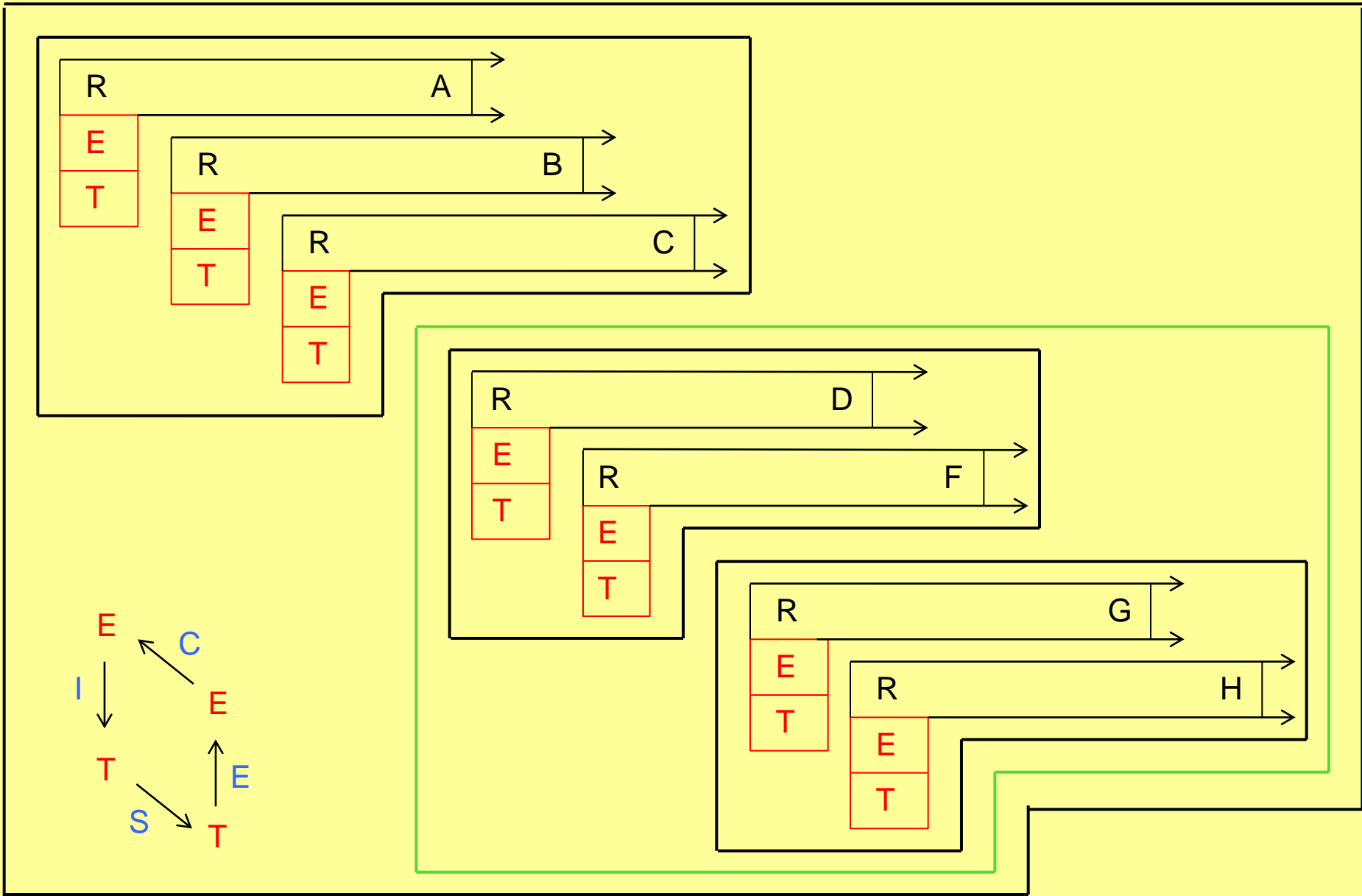

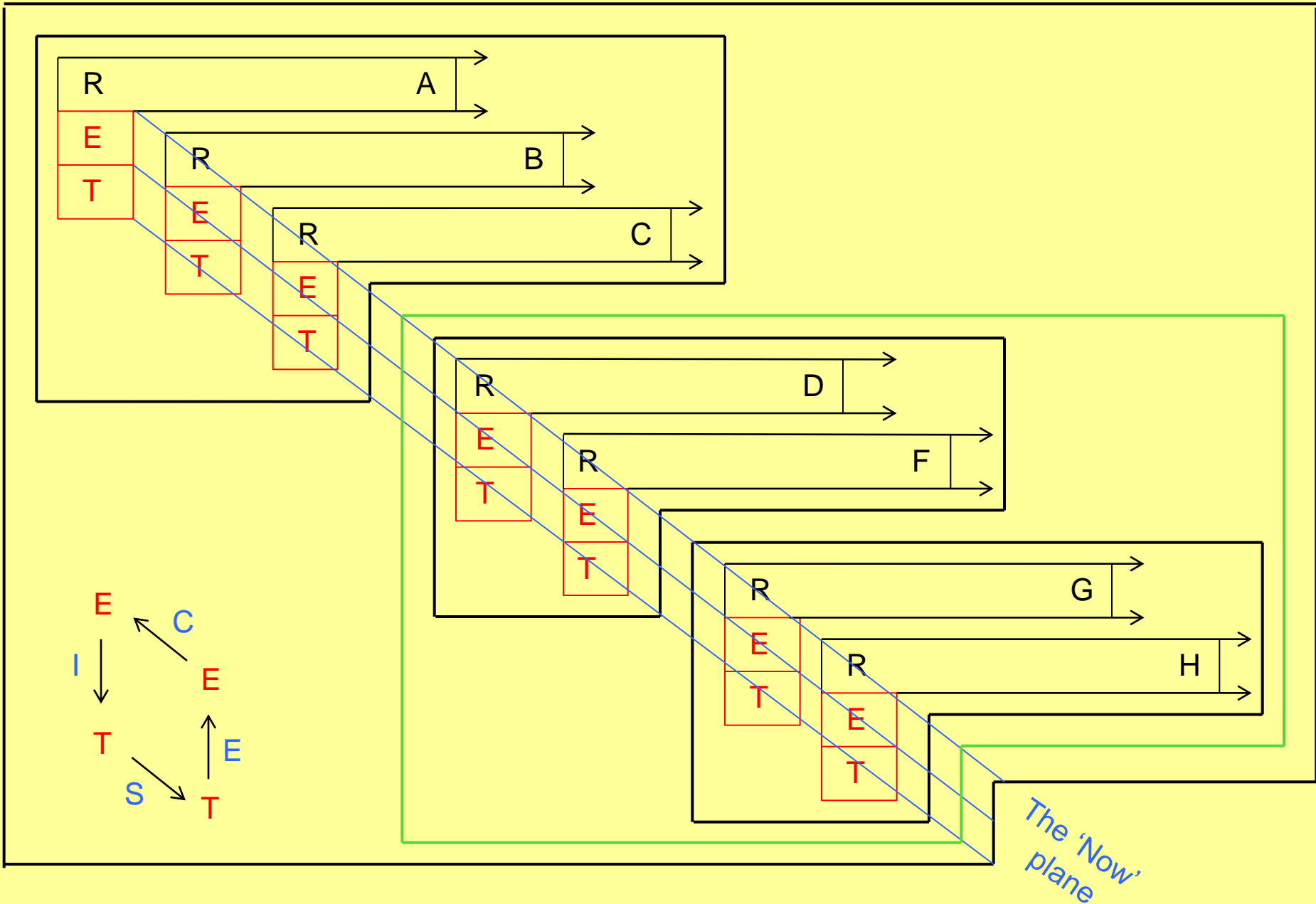

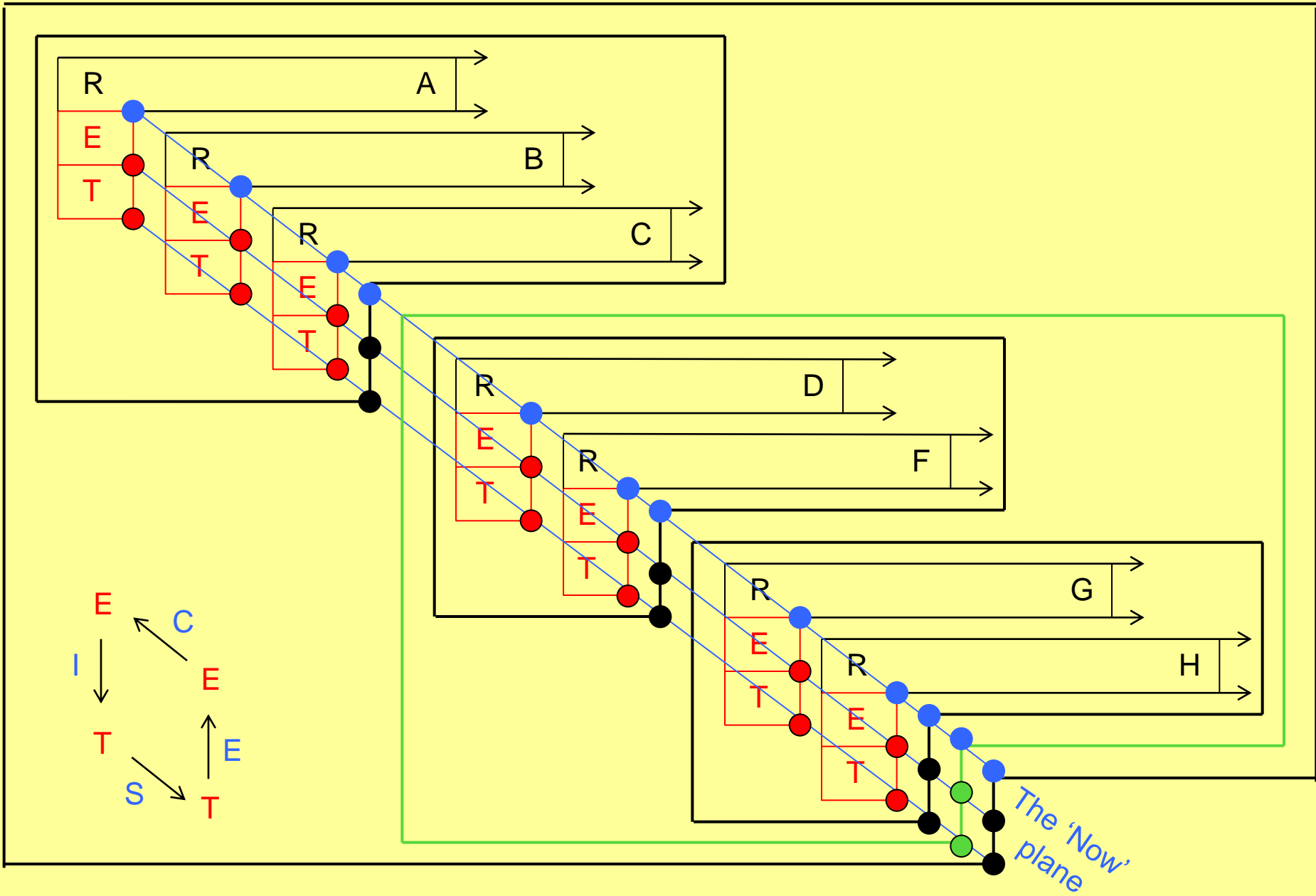

# Recursive SECI-based Communication

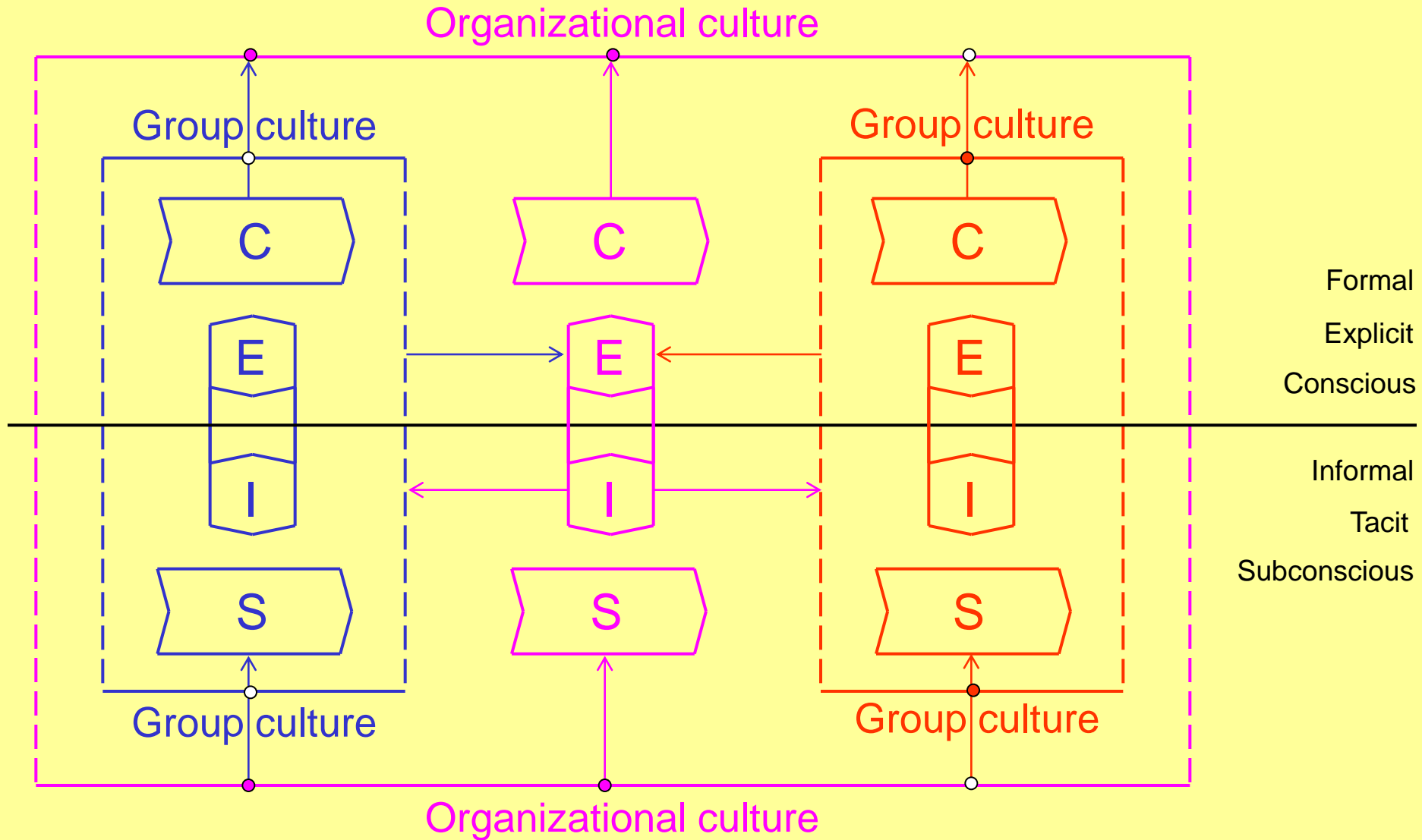

# Recursive SECI-based Communication

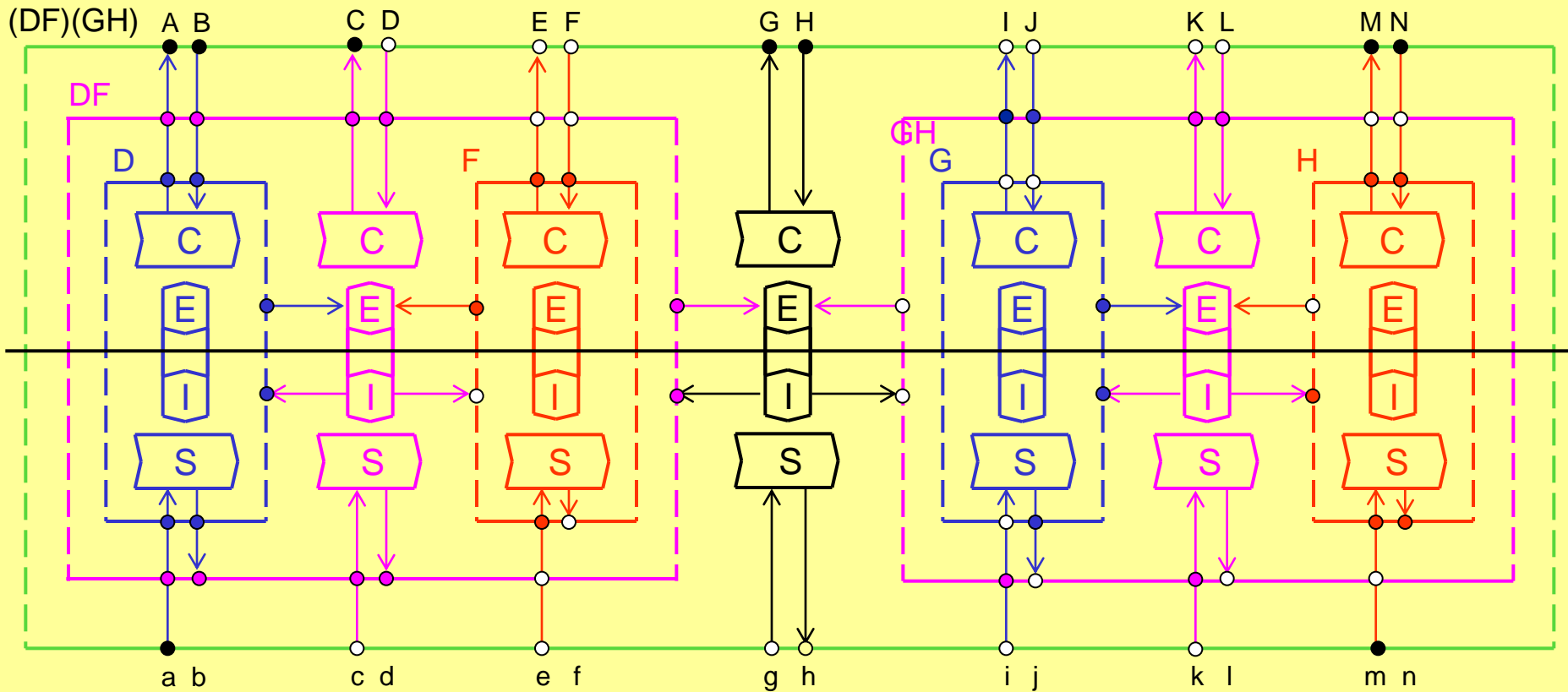

Naeve, A., et al. (2007), *A SECI-based Framework for Professional Learning Processes*, PROLEARN Deliverable D1.10, July 2007, <http://tinyurl.com/38grfjq>

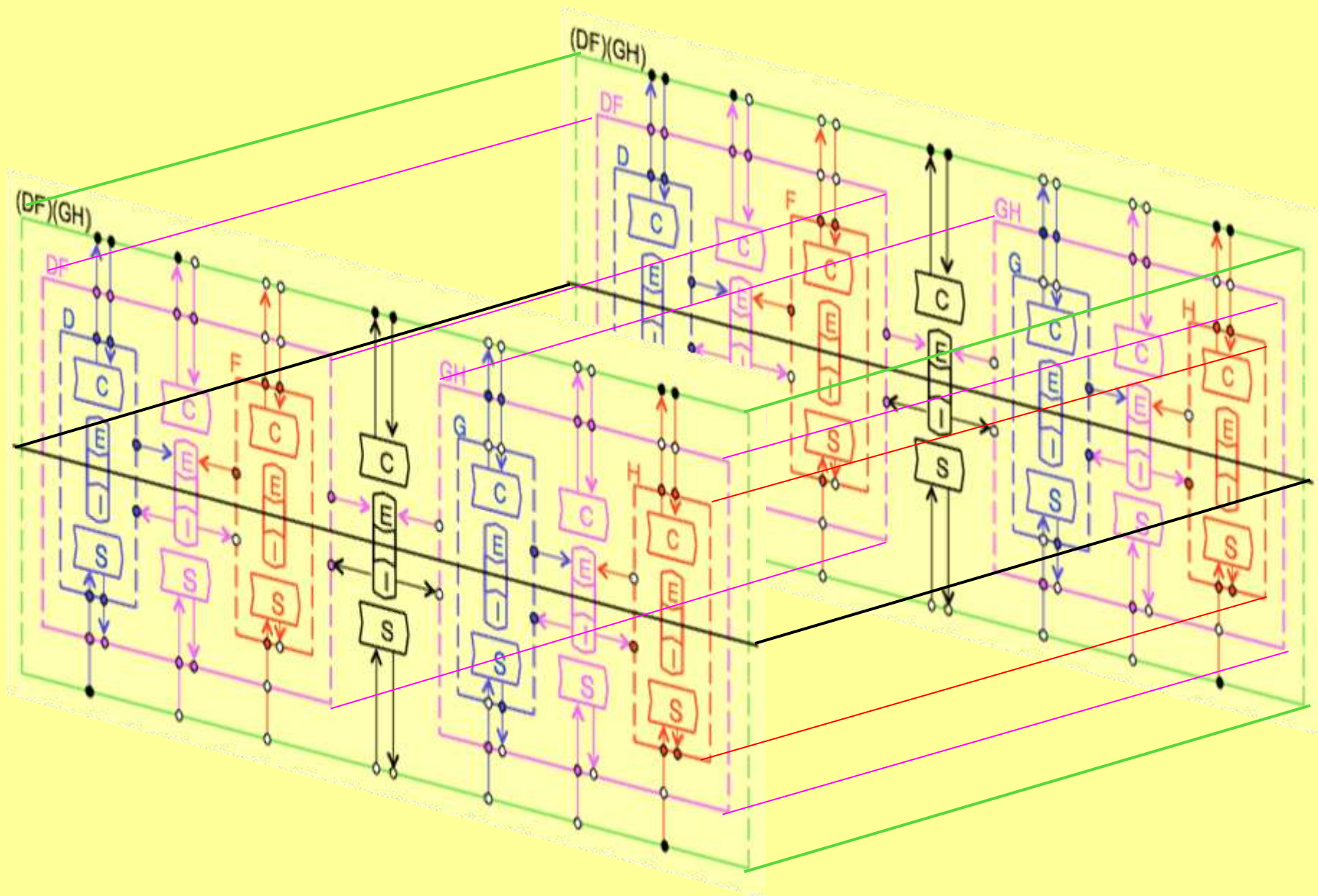



# Cultural interactions over time

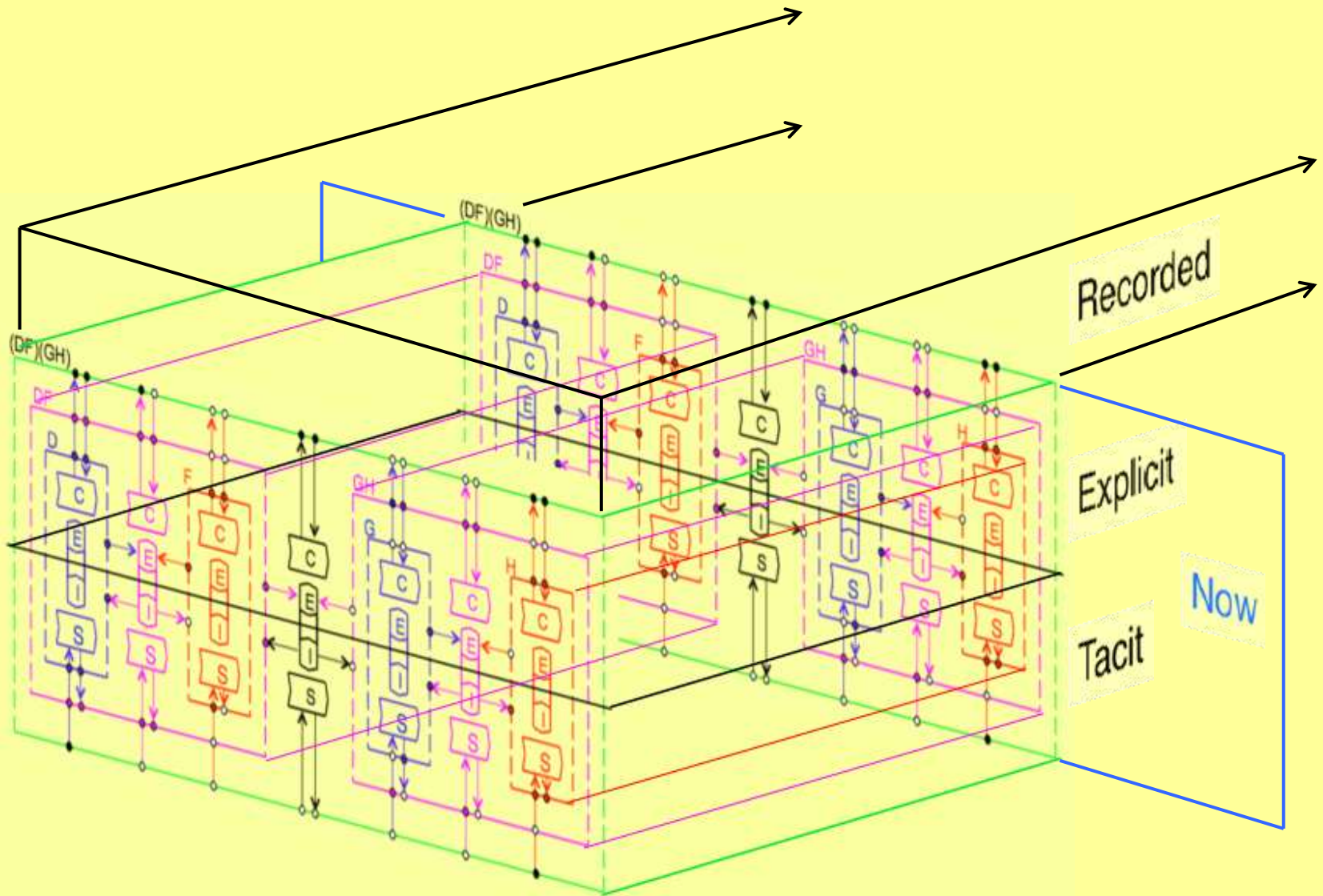

# Spaces of communication and aloneness

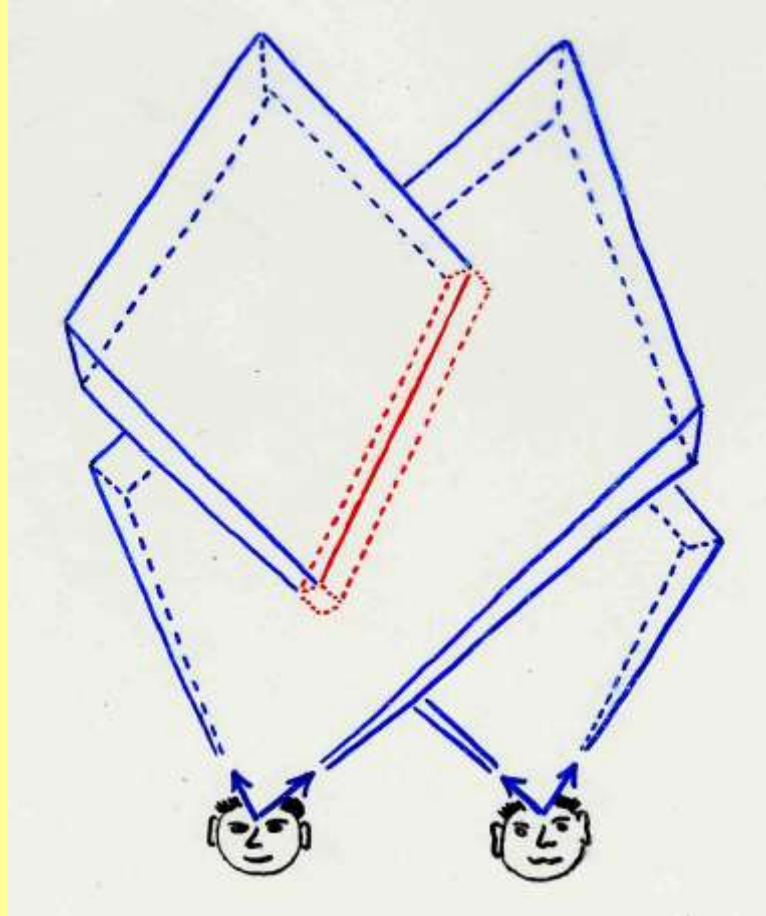

Ambjörn Naeve, San Francisco, 1976

# Explicit/Tacit connection between A and B

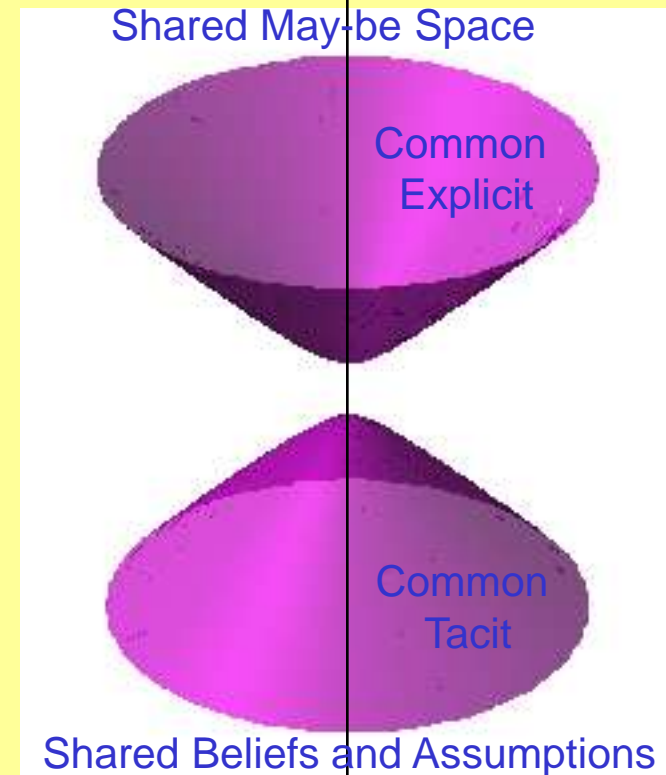
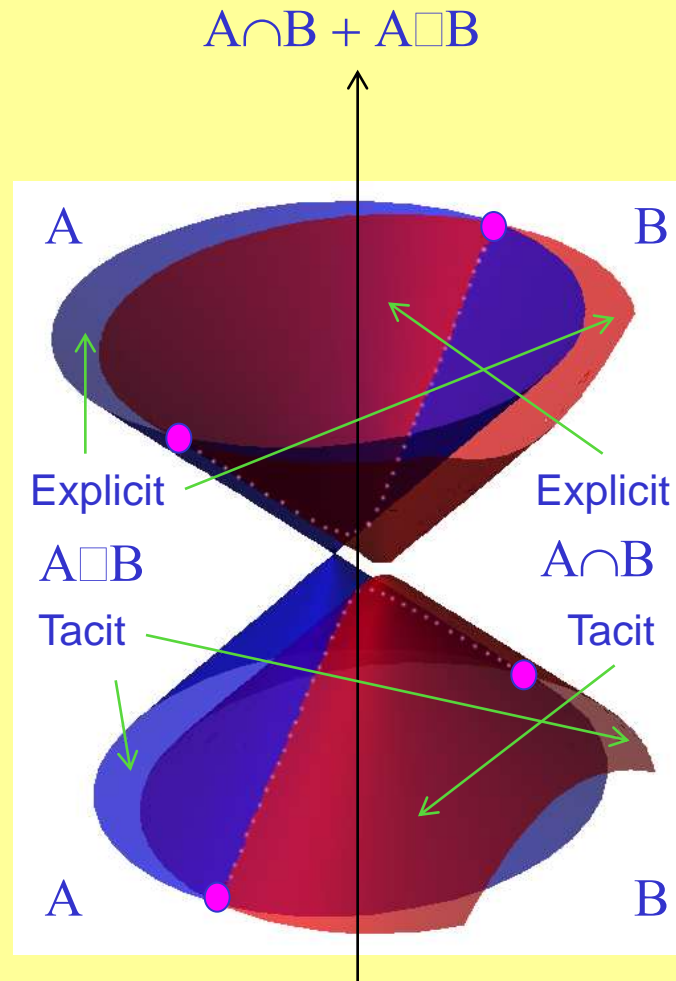
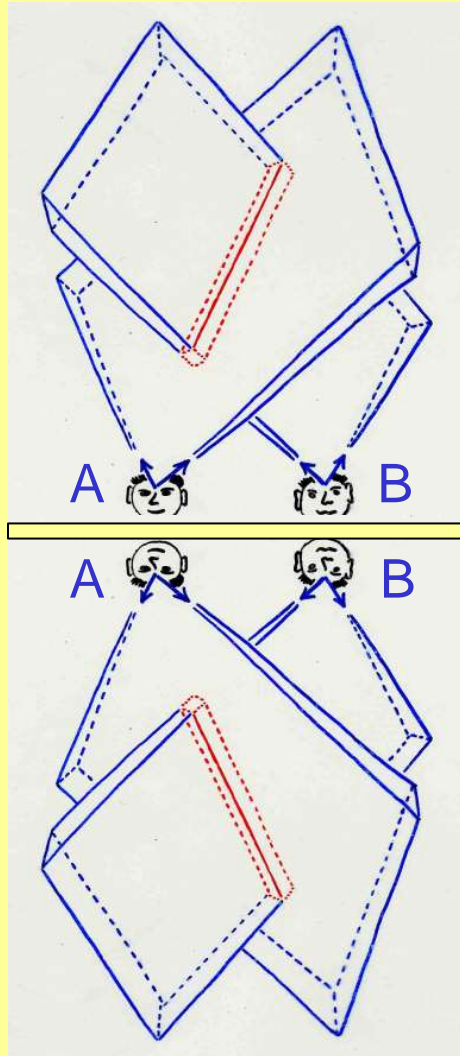

# Tacit connectivity path

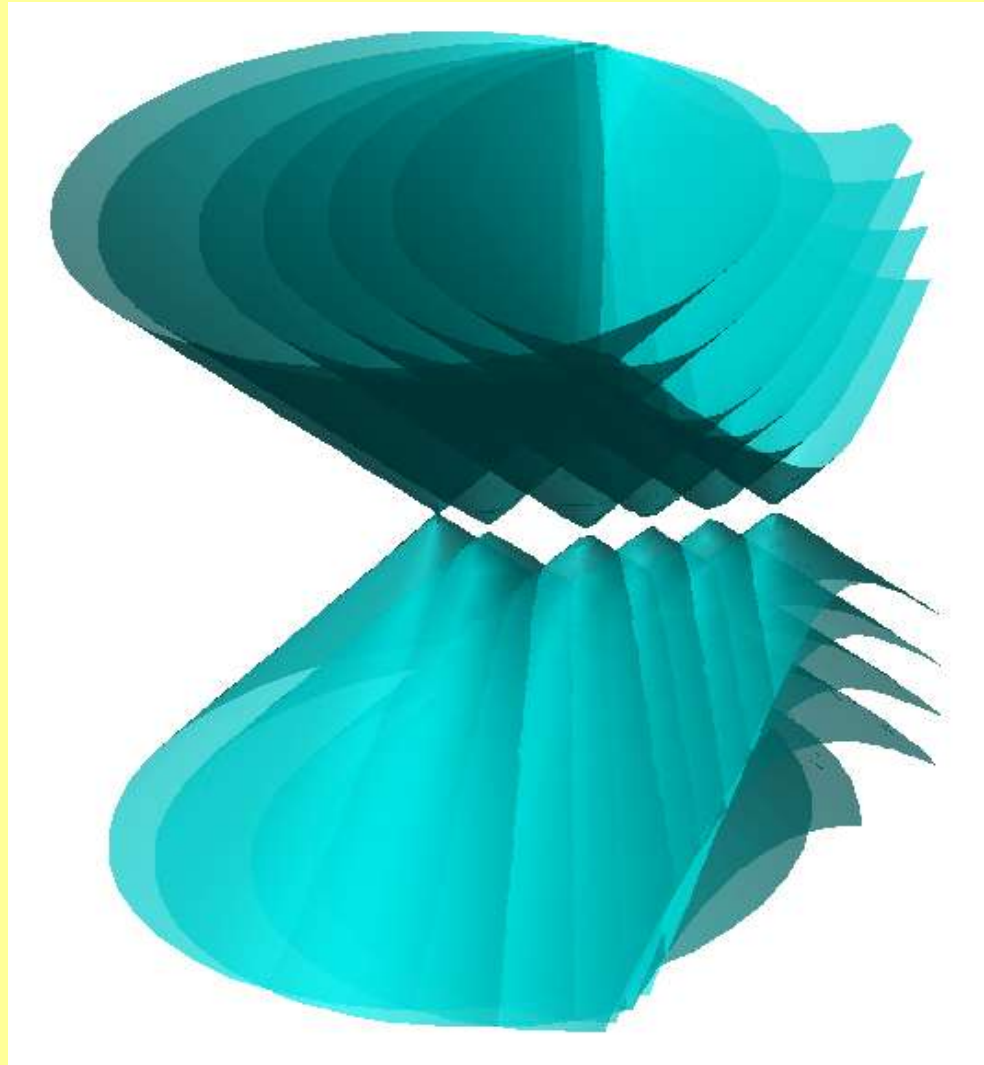

# The Human Atoll

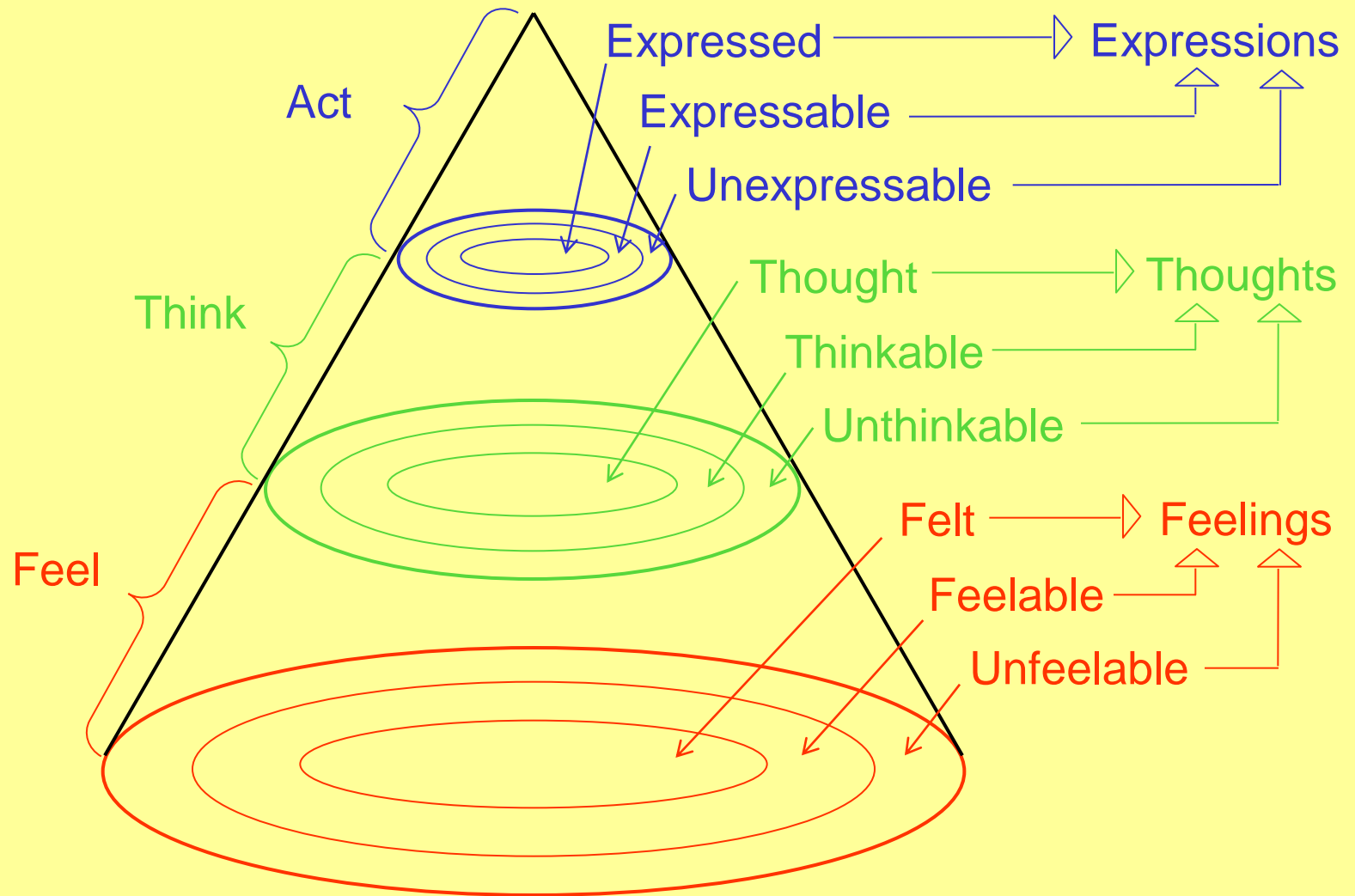

# Communication model for Human Atolls

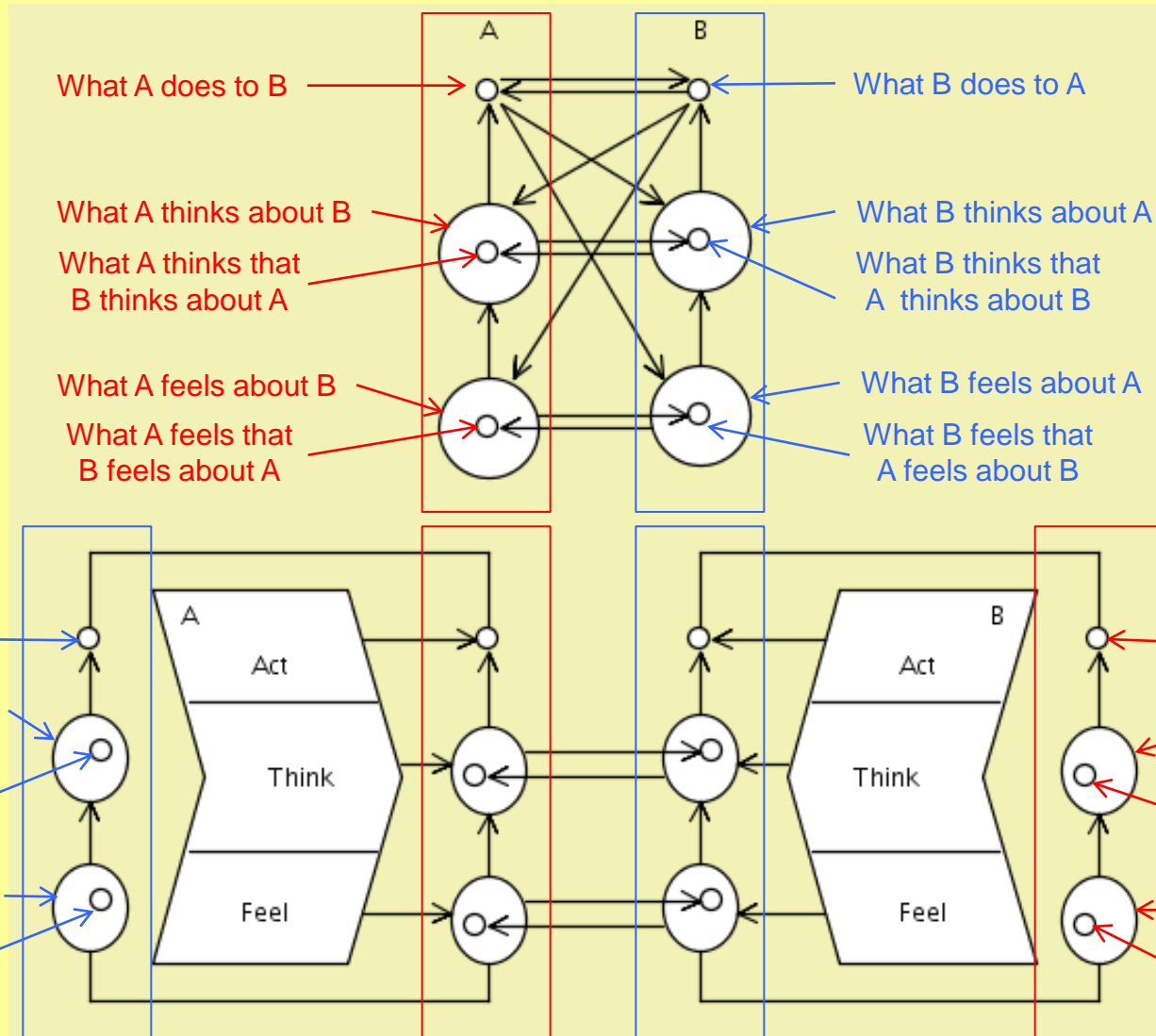

# The feedback loop of life

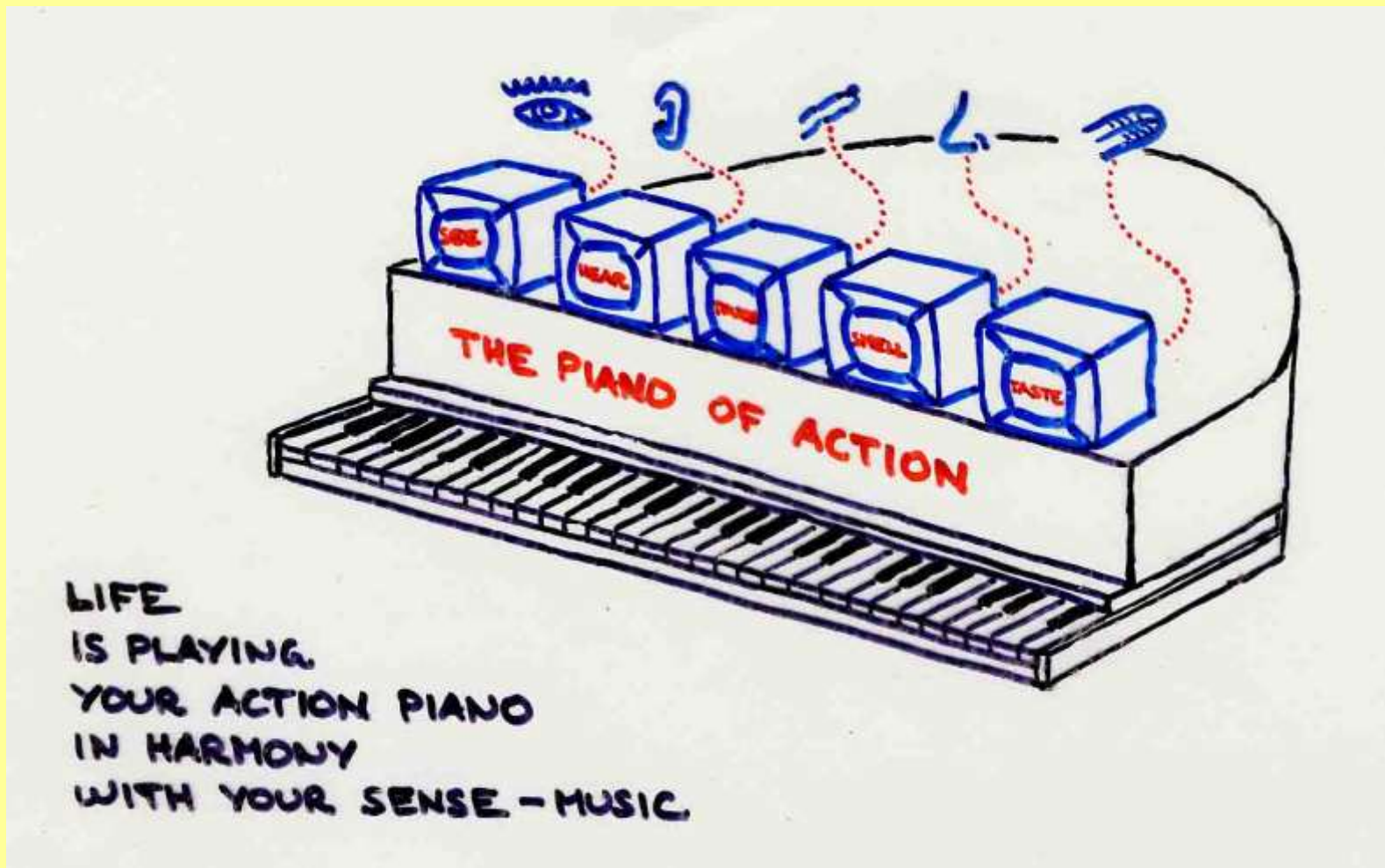

Ambjörn Naeve, San Francisco, 1976

# The action reflection loop

explain as perceived - apply as intended

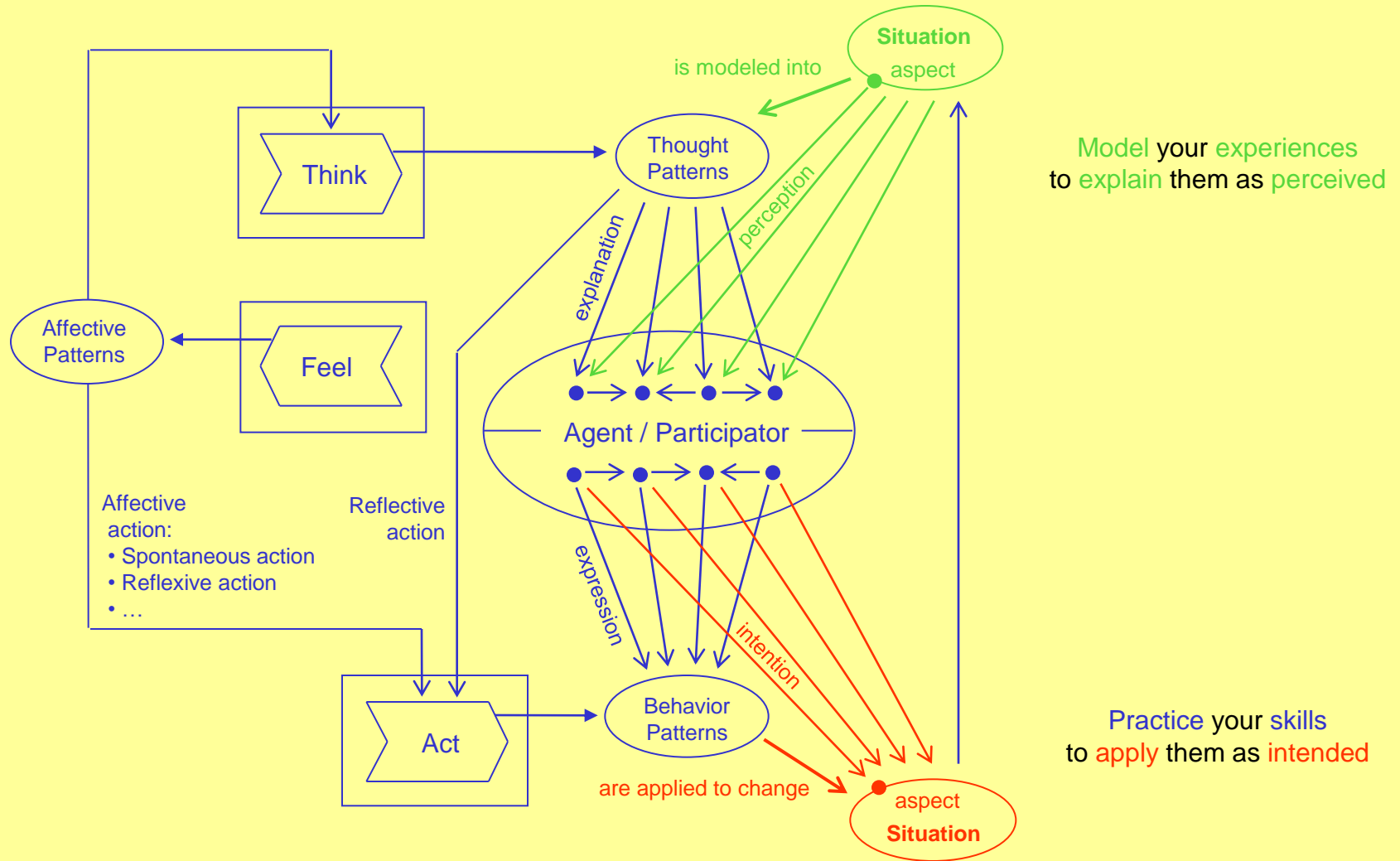



# # means good enough

## Ideas and Skills

